

SPECIFICATIONS SUBJECT TO
CHANGE WITHOUT NOTICE

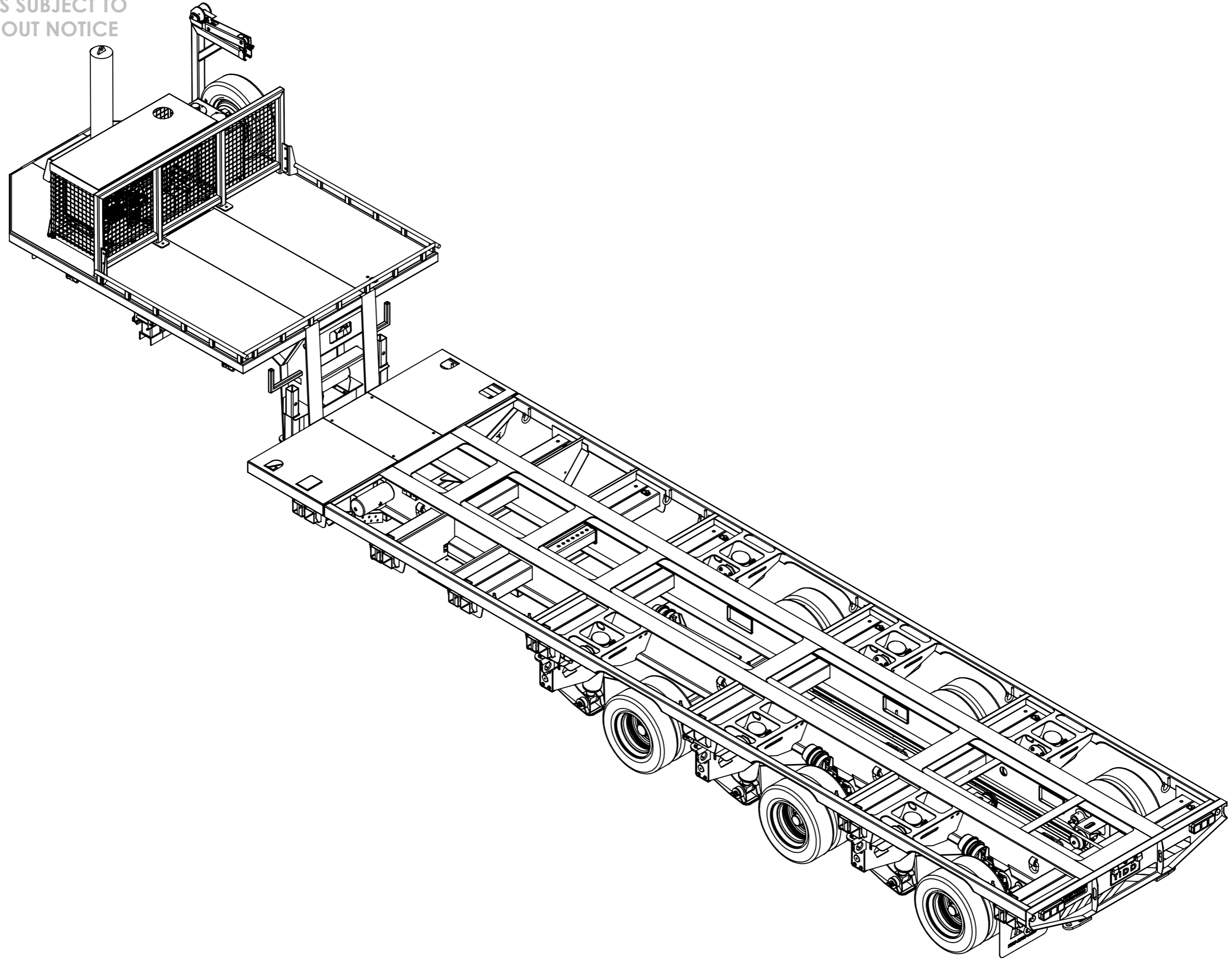

THIS DRAWING IS © COPYRIGHT AND IS THE PROPERTY OF TIDD ROSS TODD LTD. IT IS FURNISHED TO YOU FOR CONFIDENTIAL INFORMATION PURPOSES ONLY AND IS NOT TO BE DISCLOSED TO ANYONE ELSE OR USED FOR MANUFACTURING PURPOSES WITHOUT THE EXPRESS WRITTEN PERMISSION OF TIDD ROSS TODD LTD.

REV	DATE	COMMENT	NAME



TIDD ROSS TODD LIMITED

48 Maui Street
Hamilton
New Zealand
Phone +64 7 849 4839
Fax +64 7 849 3628
Email : trt@trt.co.nz
ISO 9001

	NAME	DATE
DRAWN	DT	23/04/2018
CHK'D	-	-
APPV'D	-	-

TITLE:		REVISION	
TRI AXLE HYDRAULIC HOUSE TRAILER - TWO AXLE STEER		A	
SHEET 1 OF 3	DWG NO.	309-1001W	
DO NOT SCALE DRAWINGS IN mm's	STATUS - M	SCALE:1:35	

SPECIFICATIONS SUBJECT TO
CHANGE WITHOUT NOTICE

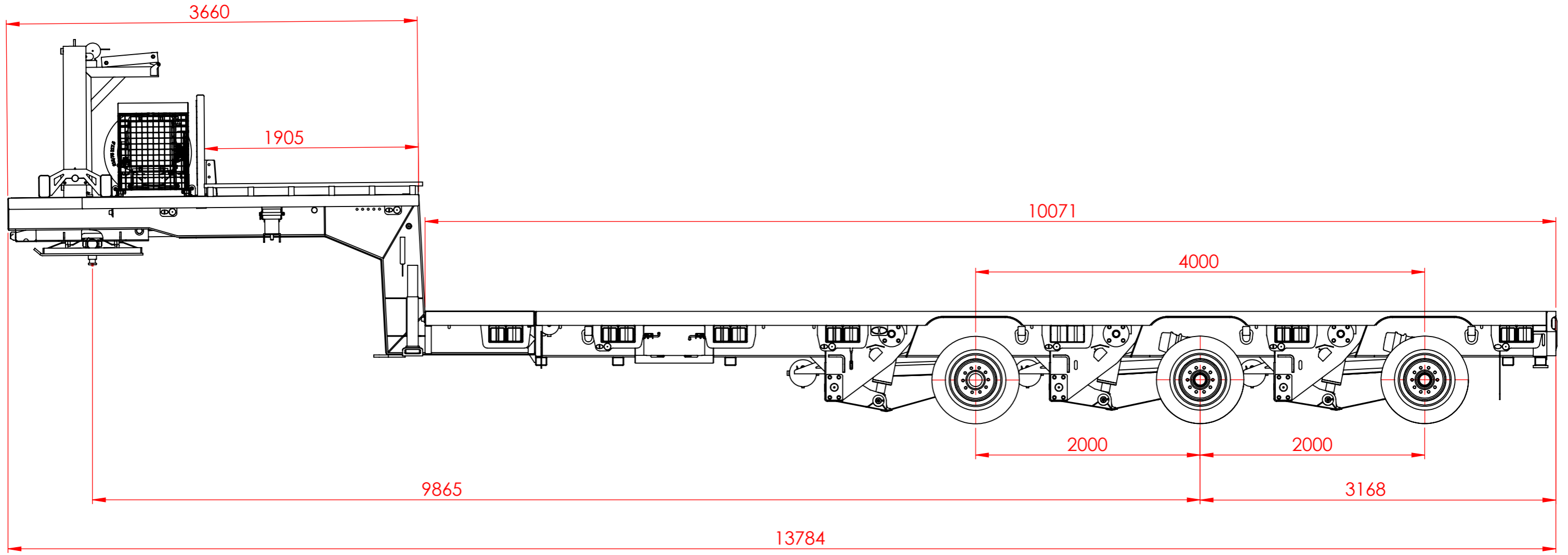
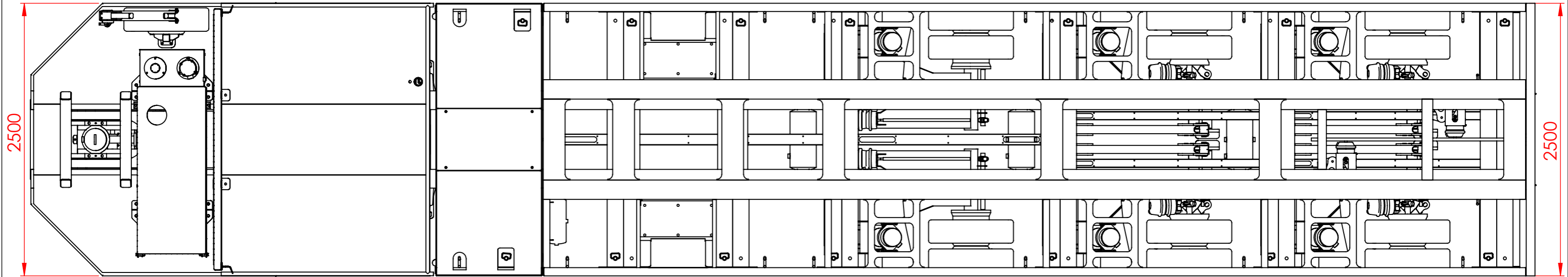

TOLERANCE : ± 0.5mm UNLESS OTHERWISE STATED
WIRE BUFF ALL STEEL COMPONENTS PRIOR TO WELDING

WELDING: ALL INFORMATION SHALL COMPLY WITH NZ/AS 1554:2000 PT 1 CATEGORY SP UNLESS OTHERWISE STATED AND SHALL BE WELDED TO A QUALIFIED PROCEDURE, BY A WELDER QUALIFIED FOR THE APPROPRIATE POSITION AND SUPERVISED BY A WELDING SUPERVISOR

THIS DRAWING IS © COPYRIGHT AND IS THE PROPERTY OF TIDD ROSS TODD LTD. IT IS FURNISHED TO YOU FOR CONFIDENTIAL INFORMATION PURPOSES ONLY AND IS NOT TO BE DISCLOSED TO ANYONE ELSE OR USED FOR MANUFACTURING PURPOSES WITHOUT THE EXPRESS WRITTEN PERMISSION OF TIDD ROSS TODD LTD.

REV	DATE	COMMENT	NAME



48 Maui Street
Hamilton
New Zealand
Phone +64 7 849 4839
Fax +64 7 849 3628
Email : trt@trt.co.nz
ISO 9001

	NAME	DATE
DRAWN	DT	23/04/2018
CHK'D	-	-
APPV'D	-	-

TITLE:		REVISION	
TRI AXLE HYDRAULIC HOUSE TRAILER - TWO AXLE STEER		A	
SHEET 2 OF 3	DWG NO.	309-1001W	
DO NOT SCALE DRAWINGS IN mm's	STATUS - M	SCALE:1:35	

SPECIFICATIONS SUBJECT TO
CHANGE WITHOUT NOTICE

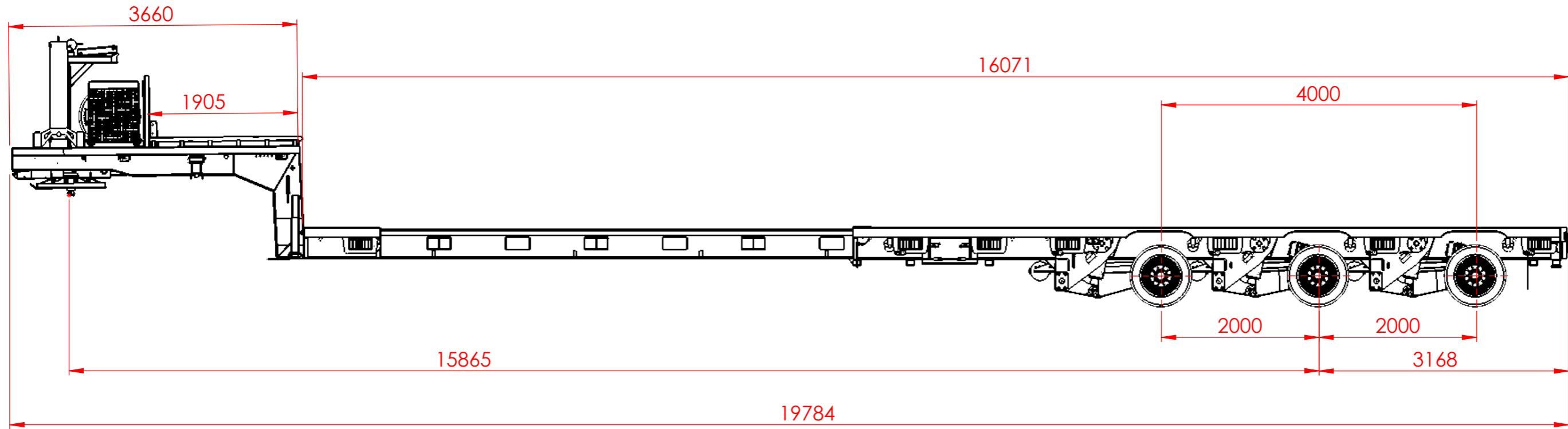
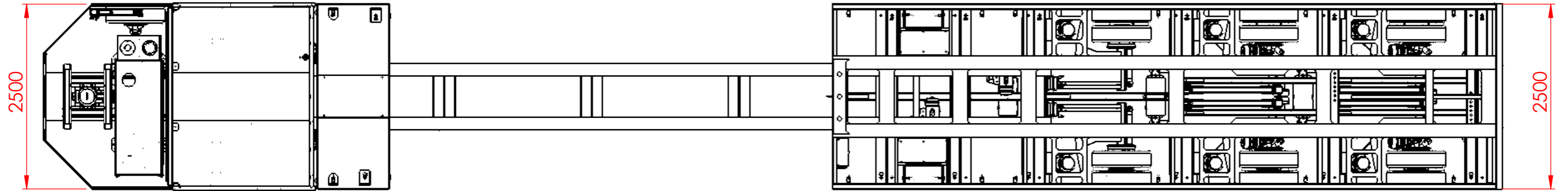

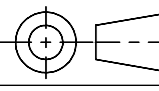
TOLERANCE : ± 0.5mm UNLESS OTHERWISE STATED
WELDING: ALL INFORMATION SHALL COMPLY WITH NZ/AS 1554:2000 PT 1 CATEGORY SP UNLESS OTHERWISE STATED AND SHALL BE WELDED TO A QUALIFIED PROCEDURE, BY A WELDER QUALIFIED FOR THE APPROPRIATE POSITION AND SUPERVISED BY A WELDING SUPERVISOR
 WIRE BUFF ALL STEEL COMPONENTS PRIOR TO WELDING
 THIS DRAWING IS © COPYRIGHT AND IS THE PROPERTY OF TIDD ROSS TODD LTD. IT IS FURNISHED TO YOU FOR CONFIDENTIAL INFORMATION PURPOSES ONLY AND IS NOT TO BE DISCLOSED TO ANYONE ELSE OR USED FOR MANUFACTURING PURPOSES WITHOUT THE EXPRESS WRITTEN PERMISSION OF TIDD ROSS TODD LTD.

REV	DATE	COMMENT	NAME



48 Maui Street
Hamilton
New Zealand
 Phone +64 7 849 4839
 Fax +64 7 849 3628
 Email : trt@trt.co.nz
 ISO 9001

NAME	DATE	TITLE:	REVISION
DRAWN DT	23/04/2018	TRI AXLE HYDRAULIC HOUSE TRAILER - TWO AXLE STEER	A
CHK'D -	-	SHEET 3 OF 3	DWG NO. 309-1001W
APPV'D -	-	SCALE:1:55	STATUS - M
DO NOT SCALE DRAWINGS IN mm's			