

# IN GEAR

OCTOBER - NOVEMBER 2021

**TRT.**  
MADE  
POSSIBLE

SAYING  
“SH\*T YEAR”  
SINCE 1967.

*Dave Carden  
founded TRT in 1967*



**TRT BRAND REFRESH.  
NEW LOOK. SAME  
DEDICATION TO  
CUSTOMER SOLUTIONS.**

PG 4

**GET GEAR:  
STEMCO/GAFF**



PG 6

# UPDATE FROM BRUCE

# TRT PARTS

I hope you all are managing well with your operations. It has been an interesting period for us all as COVID continues to disrupt how we are all able to operate, along with the routines of our teams and their families.

TRT was fortunate to be able to work through under our Essential Service Support status and the team did a great job. We are now back to full capacity and here to support all your needs.

On the 10th of September 2021, TRT unveiled a brand refresh, including a new-look logo and tagline. "TRT, for the long haul" is replaced by "TRT, Made Possible", a reflection of the innovation developed in the transport and infrastructure sectors in Australia and New Zealand, since 1967. This change is visible across branches and online platforms used by TRT.

At the heart of our rebranding is our potential to problem solve. The new bold logo and the "Made Possible" promise are rooted in the company's values and commitment to finding solutions to solve problems for our customers.

TRT's innovative focus is undeniable. Our story is driven by our competitive refusal to be beaten by the unsolvable. However, no solution to challenging problems is ever easy, but easy isn't the reason we wake up and do what we do every day. It's a key ingredient to our success and we are taking this opportunity to evolve our brand to better communicate what we represent. There are moments in a business when the time is right to reevaluate your trajectory and plan for growth. Now is that time for TRT. Our future-focused plan means embracing changes and continuously improving to make things possible.

Enjoy the latest edition of In Gear, again packed with great offers and information. Check out the great deals provided exclusively to TRT from our partner Stemco.

Continue to stay safe and reach out if we can support your operation in any way.



Innovation & Sales Group  
Director, Bruce Carden



## PARTNERS IN YOUR SUCCESS

We Know What It Takes



## EXTENSIVE RANGE

What We Don't Stock,  
We'll Source



## EXPERTS IN OUR FIELD

We Can Solve It



## KEEP YOU MOVING

Right Part, On Time

## WHAT'S HAPPENING



Scania lineup in the TRT service bay on a rainy day.



Haul Dog owner Buck Buchanan picking up his new Quad Axle Widening Low Loader.



Coupling solution designed and fabricated for a customer using a Jost fifth wheel, this ute will be able to tow a 6 tone campervan.

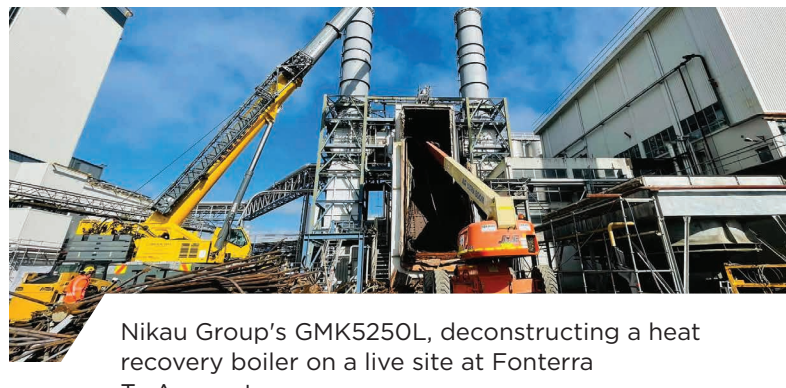

Nikau Group's GMK5250L, deconstructing a heat recovery boiler on a live site at Fonterra Te Awamutu.



# HOT DEALS



**Universal Joint**  
To suit 1810 Series. Heavy Duty  
SP15-281X

**\$51.00**

SAVE OVER 40%



**Universal Joint**  
To suit 1810 Series. Full round.  
SP5-281X

**\$105.00**

SAVE 15%



**Universal Joint**  
To suit 1710 Series. Full round.  
SP5-280X

**\$64.00**

SAVE OVER 15%



**Ashtree Mirror**  
425x230mm CONVEX  
ATM800CE

**\$49.00**

LESS THAN 1/2 PRICE



**Ashtree Mirror**  
380x190mm CONVEX  
ATM714CE

**\$29.00**

SAVE OVER 35%



**Ashtree Mirror Lamp**  
Arm Mounted LED Mini Lamp  
ATAVSWLMB2

**\$32.00**

ALMOST 60% OFF

## STEMCO Bearing and Seal Kit

To suit popular front steer axles.

AM383-0136  
AMASET049-011  
AMASET3782-20



**\$89.00**

SAVE 20%

*NEW - Follow us!  
trt\_madepossible*



**Brake Rotors**  
8 Stud non ABS to suit ROR Axle  
AM21224263NABS

**\$110.00 EA**

SAVE OVER 25%

Prices shown exclude GST & freight and are valid from 1st October to 30th November 2021 or while stocks last. No further trade discounts apply to deals shown.



# IN THE NEWS

## TRT BRAND REFRESH

### NEW LOOK. SAME DEDICATION TO CUSTOMER SOLUTIONS.

Early in September 2021, we announced our brand refresh, including a new-look logo and tagline. “TRT, Made Possible”, replacing “TRT, for the long haul”. This brand refresh is a reflection of the innovation developed in the transport and infrastructure sectors in Australia and New Zealand, since 1967. This change is visible across branches and online platforms used by TRT.

Bruce Carden, TRT’s Director of Sales and Innovation explains, “At the heart of our rebranding is our potential to problem solve. The new bold logo and the “Made Possible” promise are rooted in the company’s values and commitment to finding solutions to solve problems for customers. TRT’s innovative focus is undeniable. Our story is driven from our competitive refusal to be beaten by the unsolvable.”

Robert Carden, TRT’s Technical Director adds, “No solution to challenging problems is ever easy, but easy isn’t the reason we wake up and do what we do every day. It’s a key ingredient to our success to date and we are taking this opportunity to evolve our brand to better communicate what we represent.”

He continues, “We have always put people first at TRT. We aim to provide an environment that allows people to reach their potential and to make things possible, for our customers.”

TRT has a long history of overcoming complex engineering problems. Examples include the TIDD Pick and Carry Crane,



ESS Heavy Transport Trailers, OEM distribution agreements, and its extensive parts support network.

Dave Carden founded TRT in 1967 and it’s his legacy we’ve tried to build on over the years and now the brand refresh better represents that. Bruce Carden continues, “The brand statement “for the long haul” was built on commitment, design excellence, and trust – that’s what’s kept TRT in business for more than 54 years and we will continue to focus on our relationships with customers and fit for purpose, bumper to bumper solutions, that are made to last.”

“TRT have four very specific team values that will focus our efforts for customers - Outthink, Outserve, Own It, and Open Minds. TRT’s future-focused plan means embracing changes, and continuously improving to make things possible.”

“There are moments in a business when the time is right to reevaluate your trajectory, and plan for growth. For TRT, now is that time.” He concludes.

## Raufoss™ COUPLINGS

Raufoss air fittings are like Lego for the transport industry. You are able to build almost any combination of fitting to get the job done.

The quality of this range is undeniable. Raufoss are OEM supplies to most European trucks and EBS trailers. Try them today!

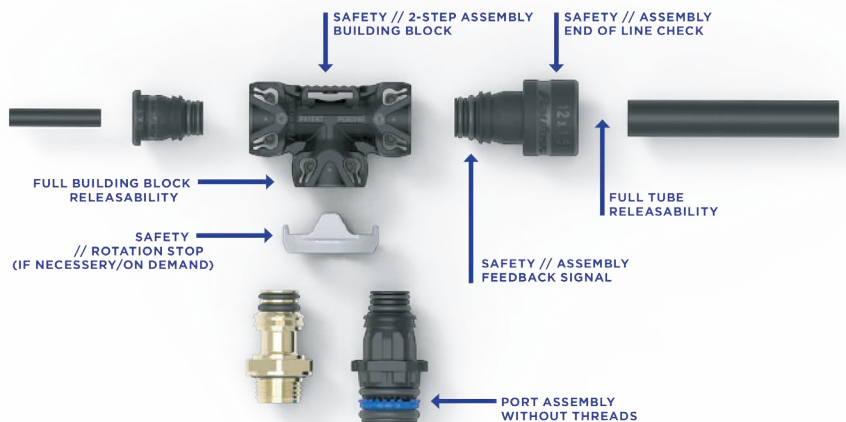

NOW AVAILABLE AT

TALK TO YOUR TERRITORY MANAGER  
FOR INFO AND OPTIONS.

# TRT

# EVERYDAY DEALS



## Stemco Centrifuse Brake Drum

American Axle Front

FTHWI90600B



## Razor Back to Front Tarp Drive

RZPN25C



## Stemco Qwikkit Kingpin

To suit MFS66 Axle

AMK131R

To suit FG9\*\* Axle

AMKG931R



## Stemco Centrifuse Brake Drum

American Axle Rear

AM89996B

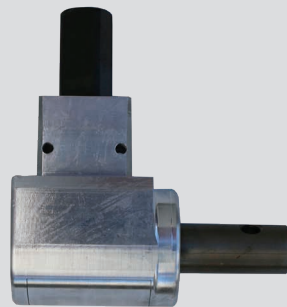

## Razor Right Angle Gearbox

RZAGR000

# DONT FORGET!

Make it easier to get our hot deals delivered to your door

**GET A TRT TRADE ACCOUNT TODAY!**

Contact us for an application form.

## JOST BALLRACE

### JOST Ballrace

1000mm 16t

JTKLKDR4100010K

1108mm 20t

JTKDR4200010K



NEW - Follow us!  
trt\_madepossible



# GET GEAR: WHY BUY STEMCO® GAFF™?

## MAKE THE CHANGE TO STEMCO® AND STEMCO® GAFF™ TODAY!

- Stemco® is a global supplier and their seals and bearings are factory fitted to several American axles as O.E.
- Stemco® is an O.E supplier for Fuwa K-hitch axles and is an O.E to Australian built Kenworth, Iveco and Daf trucks.
- Stemco® Gaff™ use a custom formula polyurethane for optimal performance and increased service life, reducing costs and downtime. It is also resistant to heat, ozone, UV, chemicals and tearing.
- Stemco® Gaff™ products have increased durability for more precise performance, when compared to similar rubber products.



### Torque Rod Bush

AM11729

**\$79.95**

O.E REF. 836940, 839310

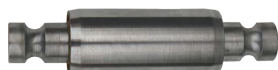

### Spring Pin Bush

AM11758

**\$115.70**

O.E REF. 296(PIN) 5295(BUSH)



### Hood Latch

AM11543

**\$21.80**

O.E REF. K147-107



### Upper Hood Hinge

AM11843

**\$39.70**

O.E REF. K066-516



### Lower Hood Hinge

AM11844

**\$61.10**

O.E REF. K066-517



### Hood Mount Left Hand

AM11840

**\$51.40**

O.E REF. R85-1236-1



### Hood Mount Right Hand

AM11839

**\$51.40**

O.E REF. R85-1236-1R



### Radiator & Cab Mount

AM11612

**\$28.10**

O.E REF. K066-177



### Motor Mount Kit Front

AM11762

**\$235.00**

O.E REF. K066-40\*



### Motor Mount Kit Rear

AM11760

**\$416.10**

O.E REF. K066-377/391/407



### Shock Absorber Bush

AM11550

**\$7.80**

O.E REF. K066-266, COM3686

Prices shown exclude GST & freight and are valid from 1st October to 30th November 2021 or while stocks last. No further trade discounts apply to deals shown.

# SEAT REPAIR + INSTALL SERVICES

## SEAT REPAIRS

You don't always need to replace your seat with a new one. We provide a complete seat repair service from minor trim and foam repairs to full refurbishments. We only use genuine replacement parts and stand behind our workmanship offering a 12-month warranty.



## SEAT COVERS

Customise your truck, machinery or ute seat covers with your company logo and protect your seat for longer!

No set-up fee with purchase of 10 or more!

## INSTALLATION

Our experienced teams can install your seat at our workshops in Hamilton, Auckland, Christchurch or our mobile service can come to your site.

With our certified adaptor plates, installation of your new seat from TRT in your repair workshop is simple.



Forestry, harvesting, spreading, tankers, stock trucks, access equipment and ag work - if your fleet travels off-highway for any reason, Traction Air CTI can improve your performance.

- Improve traction
- Reduce tyre wear
- Reduce damage to road surfaces
- Greater fuel efficiency
- Improve vehicle and driver safety

Match tyre pressure to load and road surfaces, all from the comfort of the cab!

**MANAGING TYRE PRESSURE HAS NEVER BEEN EASIER, MORE ACCURATE OR SMARTER!**



# INSTALLATION

## Te Pari Products

Te Pari Product's new Scania 650HP V8 has a new HIAB X HiDuo 258-6 Crane supplied by TRT and installed by C&C Engineering.

Te Pari Products is a livestock handling solutions manufacturer based in Oamaru. Their trucks regularly travel the length of New Zealand, and offering a south-bound freight service. The new HIAB X HiDuo 258-6 is a 23tm mid-range HIAB crane. It's a reliable workhorse, ideal for cargo management, making loading and unloading easy and safe. The HiDuo remote control ensures a responsive and safe operation that keep the load stable and boost capacity when their operators need it the most.



## PARTNERS



Please note, franchises are exclusive by region. Enquire at your local branch.

## CONTACT

FOR 24/7 PARTS SUPPORT CALL YOUR NEAREST BRANCH



### PARTS Auckland

- ☎ 09 262 0683
- ☎ 027 2881 660
- 📍 59 Ash Rd, Wiri, Manukau
- ✉ aklparts@trt.co.nz

### Hamilton (Head Office)

- ☎ 07 849 4839
- ☎ 027 6363 362
- 📍 48 Maui St, Te Rapa
- ✉ parts@trt.co.nz

### Christchurch

- ☎ 03 741 2261
- ☎ 021 197 5807
- 📍 6 Brydone Road, Hornby South
- ✉ ccparts@trt.co.nz

### SERVICE & REPAIRS

☎ 07 849 4839 - 24/7 Call Out

### SALES Crane

- Dean McIlroy - Crane Sales
- ☎ 021 719 512
- ✉ deanm@trt.co.nz

### Elton Petersen - Crane Service

- ☎ 021 0887 4742
- ✉ eltonp@trt.co.nz

### Trailers

- Glen Harnett
- ☎ 027 282 8090
- ✉ glenh@trt.co.nz

### Hiab

- Hillary Naish - National Sales Manager
- ☎ 021 486 862
- ✉ hillaryn@trt.co.nz

### Barry Munro - South Island

- ☎ 021 288 3466
- ✉ barrym@trt.co.nz

### Traction Air

- Grant Ferguson
- ☎ 027 477 7383
- ✉ grantf@trt.co.nz

www.trt.co.nz