



**KOBELCO**

**KOBELCO INTERNATIONAL (S) CO., PTE. LTD. (Singapore)**

30 Pioneer Crescent, #03 - 15 West Park Biz Central, Singapore 628560  
TEL: +65-6268-1308

**KOBELCO CONSTRUCTION EQUIPMENT INDIA PVT. LTD. (India)**

H-200, Sector 63, Noida, Distt. Gautam Budh Nagar - 201307, Uttar Pradesh, India  
TEL: +91-11-40151900

**KOBELCO CONSTRUCTION MACHINERY MIDDLE EAST AND AFRICA FZCO. (U.A.E)**

PO Box 371682, 6WA-724, Dubai Airport Free Zone, Dubai  
TEL: +971 (0)4 298 2020

**KOBELCO CONSTRUCTION MACHINERY INTERNATIONAL TRADING CO., LTD.**

7-15, Minatojima, Chuo-ku, Kobe City, Hyogo Prefecture 650-0045 JAPAN  
TEL: +81-78-303-1220 (Cranes sales)

**Kobelco Global Parts Center (Singapore)**

We supply spare parts to all over the world, mainly to Southeast Asia. Our main parts center is in Japan.

Note: This catalog may contain photographs of machines with specifications, attachments and optional equipment not certified for operation in your country. Please consult KOBELCO for those items you may require. Due to our policy of continual product improvements all designs and specifications are subject to change without advance notice.

Copyright by KOBELCO CONSTRUCTION MACHINERY CO., LTD. No part of this catalog may be reproduced in any manner without notice.

**KOBELCO CONSTRUCTION MACHINERY CO., LTD.**

5-15, Kitashinagawa 5-chome, Shinagawa-ku, Tokyo 141-8626 JAPAN  
Tel: +81-3-5789-2121 Fax: +81-3-5789-3372  
URL: <https://www.kobelcocm-global.com>

Inquiries To :

**HEAVY DUTY  
BASE MACHINES**

**FOR CIVIL ENGINEERING AND FOUNDATION WORK**

**BMS800**

**BMS1000**

**BMS1200HD**

**7120Sfs**

INSPIRING THE NEXT GENERATION OF

# MACHINES WITH POWER, SPEED AND RELIABILITY.

Engineered specifically for robust and high cycle foundation applications

These series are equipped with a wet-type disc brake with free fall and wide, large-capacity drums which are indispensable for foundation work. In addition, a high-powered engine and hydraulic pumps with a dual flow circuit are installed as standard equipment. Combined with a large hydraulic tank for duty cycle work, a variety of foundation application can be achieved easily with power and speed. In addition, due to Kobelco's unique systems and structures designed with foundation jobs in mind, hoisting and slewing during continuous high cycle work can be carried out without causing fatigue or stress on the operator. The BMS and FS series will increase customers' efficiency and productivity.

## " POWERFUL WINCH

High line-pull & High speed

- Wet-type Disc Brake
- Large-capacity Third Winch (Optional)

## " HIGH-OUTPUT ENGINE

## " DUAL HYDRAULIC FLOW CIRCUIT

Superior Synchronization of Main and Auxiliary Winches

## " SMOOTH AND ACCURATE OPERATION

## " SAFETY AND OPERATOR-ORIENTED DESIGN



# FOUNDATION APPLICATIONS WITH KOBELCO

## DIAPHRAGM WALL BUCKET / TRENCHING MILL

A Diaphragm wall bucket with teeth excavates and forms a wall by utilizing a mechanical, hydraulic, or electric system to open and close the bucket. In a Trench Mill application an attachment equipped with rotary cutters excavates the ground by pushing the rotating bit down into the ground.



Shanghai

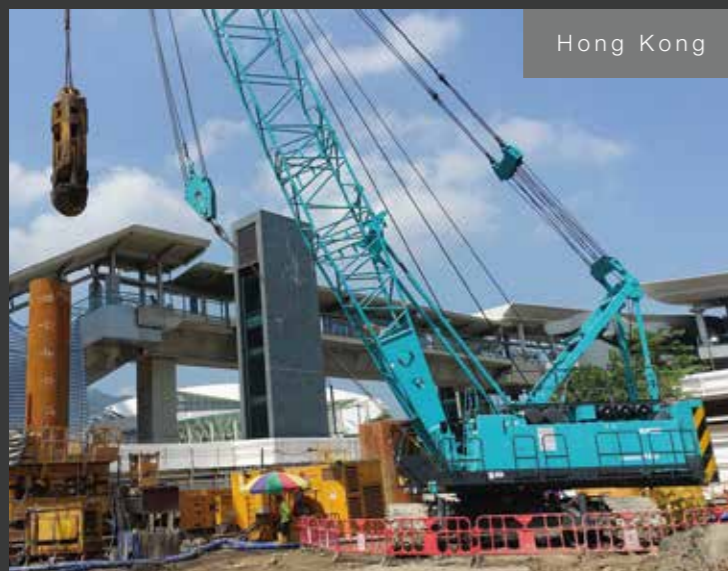

Hong Kong

## ALL CASING / CASING OSCILLATOR

The All Casing/Casing Oscillator attachment is used in a cast-in-place piling method. Underground obstacles such as small boulders or a hard layer of rock are cut or chipped away by a hammer grab bucket, and soil or rocks and sand are removed from inside the caisson/casing tube with the hammer grab. After casting the concrete, the casing tube is pulled out. A hammer grab is also used to remove existing piles.

## PILE HAMMER / PILE DRIVER

Since there is no need for pre-drilling, driving prefabricated piles with a Pile Hammer/Pile Driver is highly efficient and sufficient bearing capacity can be obtained. In the case of penetrating hard ground, first, a bored hole is drilled with an auger and then a pile is inserted into the hole and driven into the ground by the hammer.



Brazil



Algeria

## VIBRATORY-HAMMER

There are two types of vibratory hammers: electrically or hydraulically operated. Piles are driven or extracted by vertical vibration of the hammer.



New Zealand

## EARTH DRILL

The excavating bucket is filled by rotating the drilling bucket attached to the end of the Kelly bar while lowering the drill into the hole.

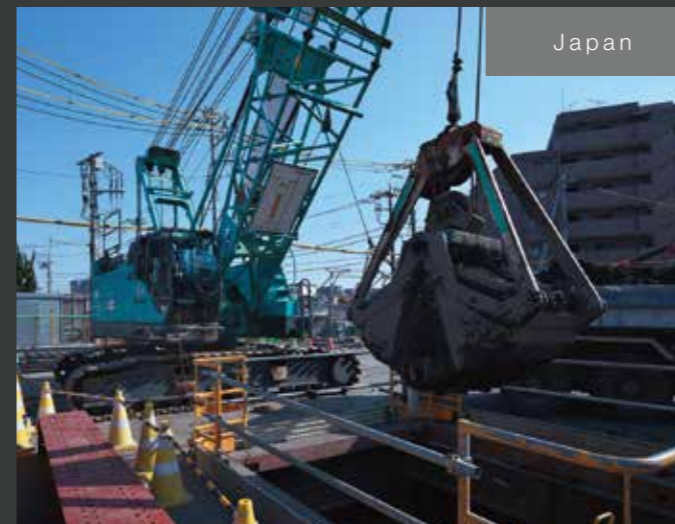

Japan

## CLAMSHELL

The main hoist and auxiliary hoist lines controls the opening and closing, as well as, lowering or raising of the clamshell bucket simultaneously. Clamshells play an important role mainly in excavating work on river beds and underground work for buildings and civil engineering.

# POWERFUL FUNCTION FOR FOUNDATION WORKS

**"STRONG WINCH**  
-HIGH LINE PULL &  
HIGH SPEED



## A strong, efficient, and stable hydraulic braking power Innovative Wet-Type Disc Brake System Design

Kobelco Construction Machinery introduced in 1997, ahead of others, a hoisting winch with wet-type disc brake, hereinafter called a wet-type disc brake winch. The BMS series and FS series include a wet-type disc brake winch with free fall as standard equipment. A wet-type disc brake winch ensures continuous braking capacity and a large braking force can be obtained with light pedal operation. Further, the disc is cooled by a forced hydraulic oil cooling type system from large hydraulic tank specifically designed for high duty cycle work especially using continuous free fall operation. This ensures precise and full braking force function is obtained. Periodical adjustment or maintenance, or change of braking discs is not necessary, hence the low running cost. As the discs are sealed, braking noise or unpleasant squeaking of the brake will not occur.

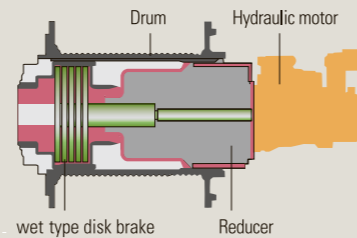

## Wide, Large-capacity Drums

The drum width of this winch is larger compared to our CKS series winches. BMS800, for example, can hold 42m (22 rows) of 26mm diameter wire rope per layer, and even in excavation to a depth of 30m to 50m using a hammer grab, the second layer wire can be sufficient. As rough reeving of the rope will hardly occur owing to the large radius, the lifespan of wire rope is extended considerably.



## High Line-pull Winches

Through the efficient matching of a high-output engine and high-performance hydraulic motors and wide drums, the winches deliver plenty of line pull. They deliver highly reliable performance for high duty cycle work.

## Large Third Winch

Specifically designed for operation using multiple attachments e.g. the main and auxiliary winch for a bucket, and the third drum for handling a casing jack.



## Dual Hydraulic Flow Circuit for Strong and Speedy Hoisting

By providing a dual flow from two pumps using a series circuit, work using a bucket application for foundation or harbor construction can be carried out at a faster pace. Even with different load on each winch, this combined flow ensures that the same line speeds are maintained on both winches during hoisting. In an operation with a diaphragm wall buckets where synchronizing is necessary, the operation can be achieved smoothly. On the BMS1200HD and 7120SFS, since the boom hoist circuit utilizes an independent pump, simultaneous operation of the hoist drum and boom hoist is smooth and without disruption.

**"HIGH-OUTPUT**  
ENGINE



The BMS800 & BMS1000 series incorporate a larger horse power engine, which is one class higher than a multi-purpose crawler crane of the same class. Using an efficient and high horse power engine enables the crane to perform and operate in difficult work situations in a more safe and efficient manner by a wide margin. Faster operation, for example using a clamshell can achieve greater work volume.



## POWERFUL SPEC FOR FOUNDATION WORKS

Model	BMS800		CKS800	BMS1000		CKS1100	BMS1200HD	7120SFS	7120S	
		OPTIONAL			OPTIONAL					
Wire Rope Diameter	Main	26mm	28mm	22mm	28mm	30mm	26mm	36mm	30mm	26mm
	Aux.	26mm	28mm	22mm	28mm	30mm	26mm	36mm	30mm	26mm
	Third	26mm	26mm	22mm	26mm	26mm	26mm	30mm	26mm	26mm
Drum Width (Main/Aux.)	617mm	620mm	545mm	620mm	617mm	617mm	1055mm	617mm	617mm	
Line Pull (Main/Aux.)	108kN	108kN	69kN	132kN	132kN	108kN	157kN	152kN	108kN	
Max. Line Pull (Main/Aux.)	208kN	252kN	155kN	252kN	252kN	208kN	336kN	252kN	208kN	
Engine Output	271kW	271kW	213kW	271kW	271kW	213kW	634kW	271kW	271kW	

=Multi-purpose crawler crane of the same class

## Reinforcement of Rotating Frame and Boom

The structure of the rotating frame in the BMS series and that of the upper and lower boom in the 7120SFS, have been strengthened and designed for continuous high duty cycle foundation work.

# SMOOTH AND PRECISE CONTROLS



## Winch Speed Controller

The hoisting speed of the main winch and the auxiliary winch, as well as the luffing speed of the boom, can be adjusted smoothly with a dial in step less transmission during simultaneous operations.



## Smooth and Effortless Lever Operation

The control levers regulate the pilot valves directly to reduce the amount of play and ensure smooth, precise hoisting start-ups and inching. Control of crane functions is simple, easy, and precise even over long operating periods. With the additional detent function setting on the hoisting lever, the operator's stress level will be greatly reduced while operation with heavy loads during extended operation.



## Slewing "Feeling"

For slewing operation, a hydraulic pilot system has been adopted to reduce the need for operating force. Use the Kobelco's unique "Reaction force sensing system" has been added. With this system, pressure under load of the swing motor is directed to a remote-control valve and the feedback force is transferred to the swing lever. The degree and amount of this accelerating force or reducing force will be felt directly at the operator's hand through the control lever. Therefore, operation of heavy load swing or light load swing can be safely accomplished based on this feedback.



# SAFETY AND OPERATOR-ORIENTED DESIGN

## Safety Devices on the Free-fall Winch

- Free-fall operations can only be initiated by releasing the lock using a key switch. Unless the lock is released, free-fall cannot occur even if the switch is put in the "neutral-free" position. Also, to prevent the free-fall mode from being activated accidentally because of system malfunction, a monitoring function monitors the free-fall clutch cylinder pressure in the winch.
- Free-fall Switch with Interlock

The free-fall switches are strategically located on the hoist levers, allowing the operator to engage free-fall without removing his hands from the control levers. To prevent the load from accidentally dropping, the interlock function makes it impossible to initiate free-fall unless the foot brake is fully depressed. To prevent the load from accidentally dropping because of operator error, do not use free-fall when hoisting.

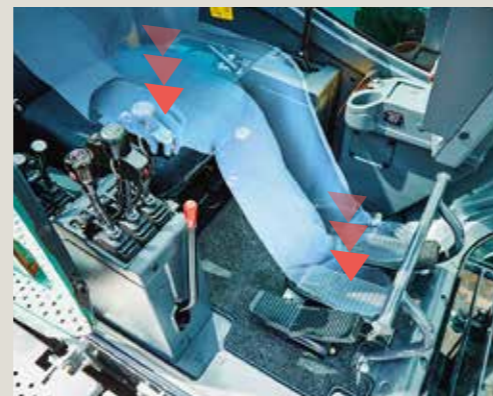

KOBELCO has developed a remote operation management system for our cranes. Machines fitted with this system transmit working condition, location, and maintenance history to provide owners with fact-based information that gives tremendous advantages for their asset management.

## Main Functions

- Managing Safety / Operational Records and Monitoring Working Status
- Acquire Working Condition and Location of the Fleet
- Preventive Maintenance Ensures Good Machine Condition and Protects Value
- Remote Failure Diagnosis

### Detailed Machine and Operation Data Can Be Accessed over the Internet

Operating data for a given crane can be accessed and accurately monitored from the Internet terminal in the crane owner's office.

#### Main Data Handled

- Map: Shows past and latest locations and travel history of all machines in the owner's fleet.
- Performance record: Hours of operation, Lift operations, and Safety record in the period of a day, a week, or other desired span.
- At-a-glance function: Outputs a report (in the form of a record log or sheet) that shows whether or not the machine is currently operating, its total operating hours, and other operating data.

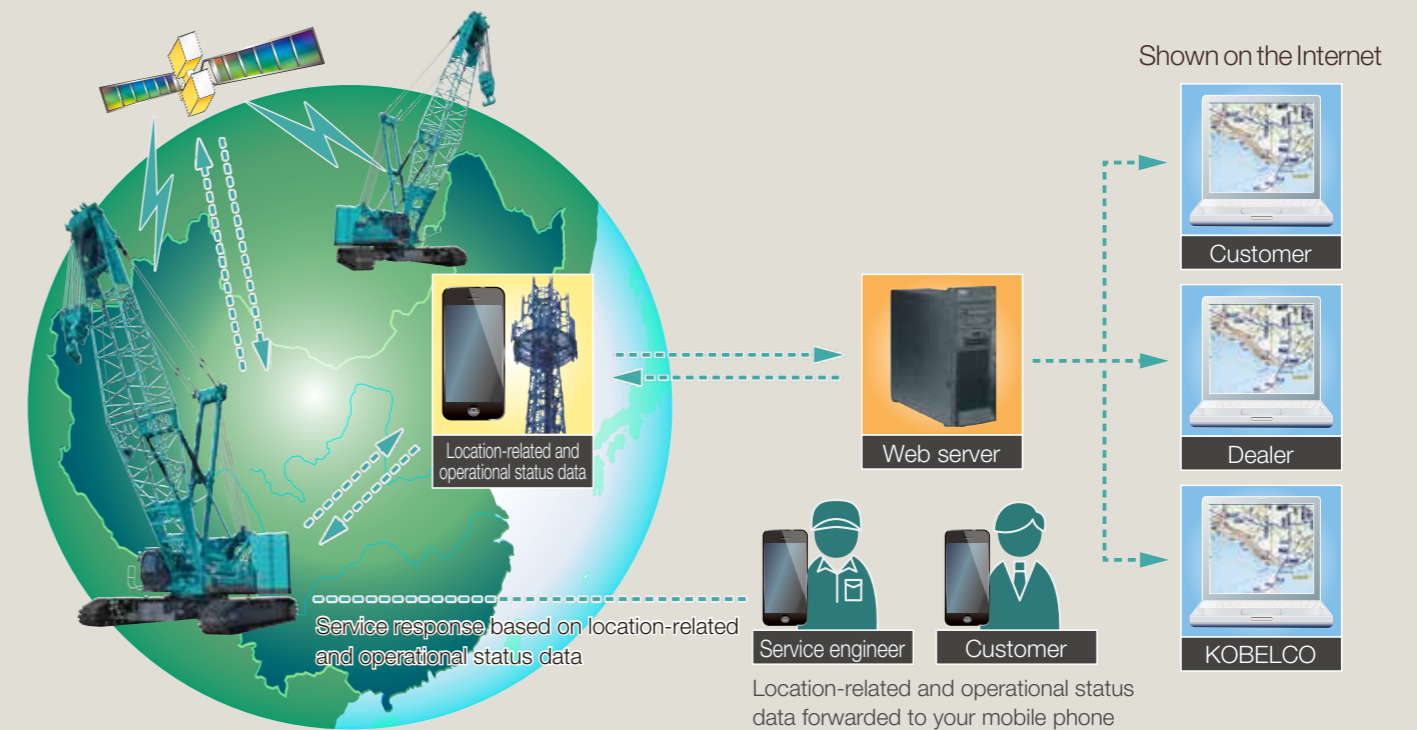

## OPTIONAL

### Hydraulic Power Source Outlet

Hydraulic power to run the attachments for various foundation applications can be sourced from the base machine and supplied to the attachment.  
\*Customized application

### Double Auxiliary Sheave

In hammer grab work, use of two-point hoisting, i.e. a bucket on the auxiliary winch and the crown on the main winch, is possible. Further, on the point sheave, the wire rope from the third drum (optional) can be reeved and a large-capacity hook that can take multi-parts of line can be equipped and the scope of possible work is thereby expanded. As bucket and handling work can be done without changing the wire rope, work efficiency is thus improved.

### Main Specifications (Model: BMS800)

Crane Boom	
Max. Lifting Capacity	80t x 3.6m
Max. Length	54.9m
Main & Aux. Winch	
Max. Line Speed (1st layer)	120m/min
Rated Line Pull (Single line)	108kN {11.0tf}
Wire Rope Diameter	26mm/28mm (opt)
Wire Rope Length	175m (Main), 130m (Aux.)
Brake Type (free fall)	Wet-type multiple disc brake (Standard)
Working Speed	
Swing Speed	4.0min <sup>-1</sup> {rpm}
Travel Speed	1.7/1.2km/h
Power Plant	
Model	HINO P11C-VH
Engine Output	271kW/1,850min <sup>-1</sup>
Fuel Tank	400 liters

Hydraulic System	
Main Pumps	3 variable displacement
Max. Pressure	31.9MPa {325kgf/cm <sup>2</sup> }
Hydraulic Tank Capacity	440 liters
Weight	
Operating Weight	76.0t *1
Ground Pressure	85.8kPa
Counterweight	25,400kg
Transport Weight	48,630kg *2

Units are SI units. { } indicates conventional units.  
Line speeds in table are for light loads. Line speed varies with load.  
\*1 Including upper and lower machine, 25.4 ton counterweight, 6.5 ton carbody weight, basic boom, hook, and other accessories.  
\*2 Base machine with boom base, gantry, crawlers, and wire ropes (front/rear/boom hoist), crane backstop.

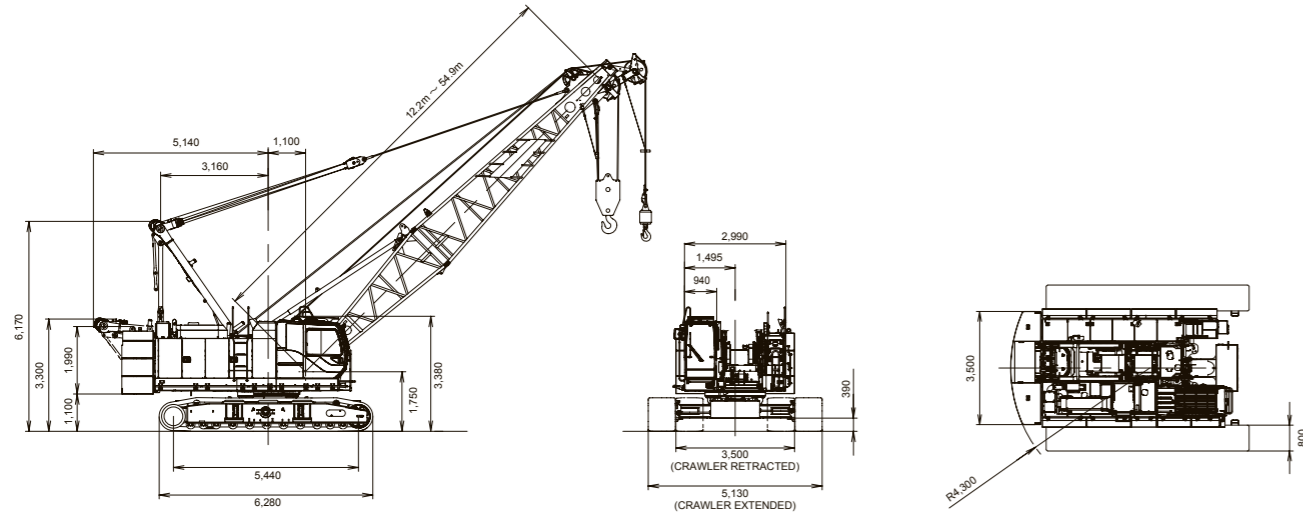

### Main Specifications (Model: BMS1000)

Crane Boom	
Max. Lifting Capacity	100t x 3.8m
Max. Length	62.6m
Main & Aux. Winch	
Max. Line Speed (1st layer)	110m/min
Rated Line Pull (Single line)	132kN {13.5tf}
Wire Rope Diameter	28mm/30mm (opt)
Wire Rope Length	200m (Main), 130m (Aux.)
Brake Type (free fall)	Wet-type multiple disc brake (Standard)
Working Speed	
Swing Speed	3.2min <sup>-1</sup> {rpm}
Travel Speed	1.4/1.0km/h
Power Plant	
Model	HINO P11C-VH
Engine Output	271kW/1,850min <sup>-1</sup>
Fuel Tank	400 liters

Hydraulic System	
Main Pumps	3 variable displacement
Max. Pressure	31.9MPa {325kgf/cm <sup>2</sup> }
Hydraulic Tank Capacity	440 liters
Weight	
Operating Weight	107t *1
Ground Pressure	109kPa
Counterweight	37,140kg
Transport Weight	31,000kg *2

Units are SI units. { } indicates conventional units.  
Line speeds in table are for light loads. Line speed varies with load.  
\*1 Including upper and lower machine, 37.1 ton counterweight, 14.6 ton carbody weight, basic boom, hook, and other accessories.  
\*2 Base machine with boom base, gantry, and wire ropes (front/rear/third/boom hoist), crane backstop.

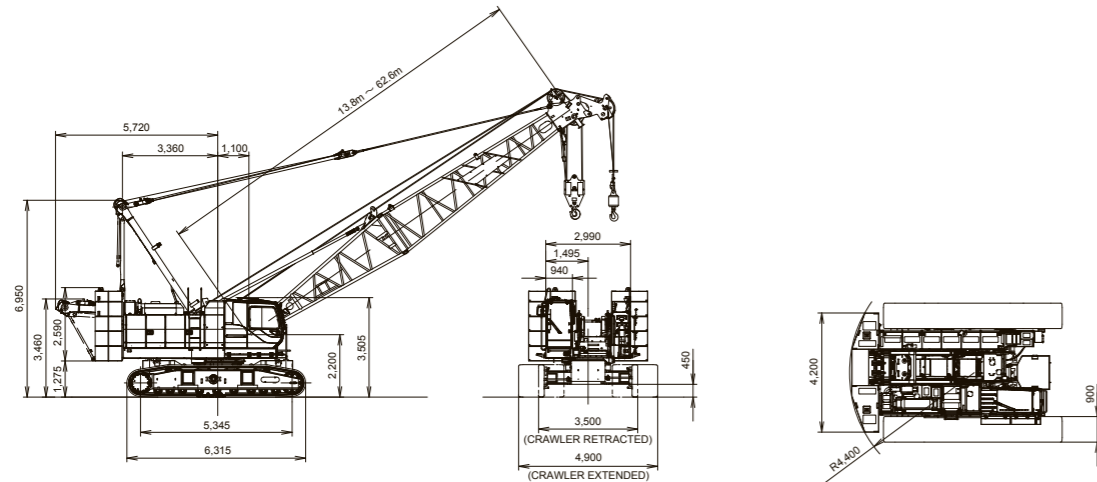

### Main Specifications (Model: BMS1200HD)

Crane Boom	
Max. Lifting Capacity	120t x 5.0m
Max. Length	61.0m
Main & Aux. Winch	
Max. Line Speed (1st layer)	110m/min
Rated Line Pull (Single line)	157kN {16.0tf}
Wire Rope Diameter	36mm
Wire Rope Length	245m (Main), 175m (Aux.)
Brake Type (free fall)	Wet-type multiple disc brake (Standard)
Working Speed	
Swing Speed	2.1min <sup>-1</sup> {rpm}
Travel Speed	1.2/0.8km/h
Power Plant	
Model	MTU 12V2000
Engine Output	634kW/1,800min <sup>-1</sup>
Fuel Tank	900 liters

Hydraulic System	
Main Pumps	8 variable displacement
Max. Pressure	32MPa {326kgf/cm <sup>2</sup> }
Hydraulic Tank Capacity	1,000 liters
Weight	
Operating Weight	116t *1
Ground Pressure	79kPa
Counterweight	32,500kg
Transport Weight	46,900kg *2

Units are SI units. { } indicates conventional units.  
Line speeds in table are for light loads. Line speed varies with load.  
\*1 Including upper and lower machine, 32.5 ton counterweight, basic boom, hook, and other accessories.  
\*2 Base machine with gantry, wire rope (front/rear/boom hoist), without crawler, auxiliary platform and duct.

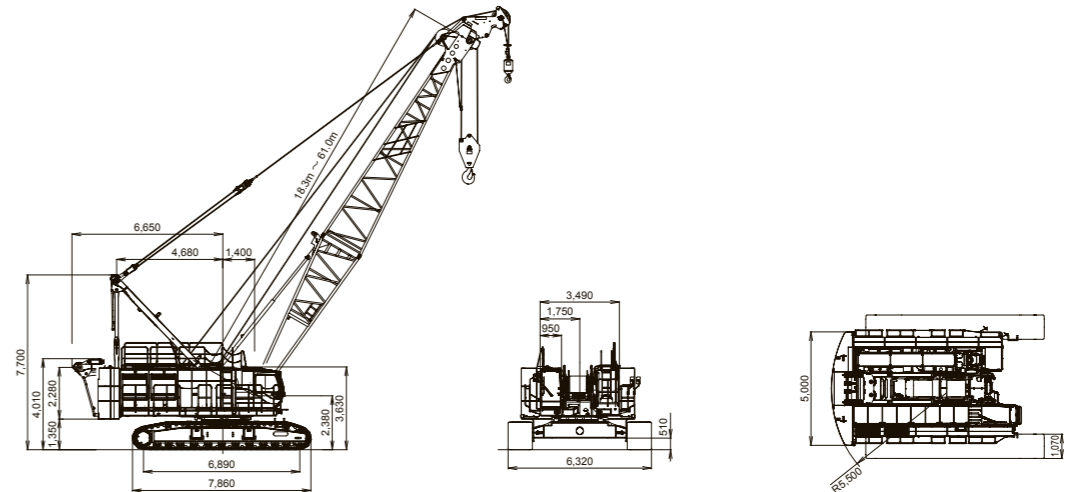

### Main Specifications (Model: 7120SFS)

Crane Boom	
Max. Lifting Capacity	120t x 5.0m
Max. Length	61.0m
Main & Aux. Winch	
Max. Line Speed (1st layer)	110m/min
Rated Line Pull (Single line)	152kN {15.5tf}
Wire Rope Diameter	30mm
Wire Rope Length	200m (Main), 130m (Aux.)
Brake Type (Free fall)	Wet-type multiple disc brake
Working Speed	
Swing Speed	2.1min <sup>-1</sup> {rpm}
Travel Speed	1.3/0.9km/h
Power Plant	
Model	HINO P11C-VH
Engine Output	271kW/1,850min <sup>-1</sup>
Fuel Tank	400 liters

Hydraulic System	
Main Pumps	4 variable displacement
Max. Pressure	31.9MPa {325kgf/cm <sup>2</sup> }
Hydraulic Tank Capacity	535 liters
Weight	
Operating Weight	137t *1
Ground Pressure	107kPa
Counterweight	59,110kg
Transport Weight	37,800kg *2

Units are SI units. { } indicates conventional units.  
Line speeds in table are for light loads. Line speed varies with load.  
\*1 Including upper and lower machine, 59.1 ton counterweight, 10.8 ton carbody weight, basic boom, 120 t hook, and other accessories.  
\*2 Base Machine with boom base gantry, wire ropes (front/rear/third/boom hoist), crane backstop (strong type).

