



# model 8500

## features

- 80 t (85 USt) Lift Capacity
- 282 t-m (2,041 ft-kips) Maximum Load Moment
- 61,0 m (200 ft) Heavy-Lift Boom
- 73,2 m (240 ft) Fixed Jib on Heavy-Lift Boom
- 159 kW (213 HP) engine
- 160 mpm (525 fpm) line speed
- 14 500 kg (32,000 lb) Maximum Line Pull
- 7 700 kg (17,000 lb) Rated Line Pull
- 7 300 kg (16,000 lb) Material Rehandling Clamshell capacity
- Fast, efficient self-assembly and disassembly
- Manitowoc Crane CARE comprehensive support



**product  
guide**



## contents

Specifications

3

Outline Dimensions

6

Self Assembly

10

Boom Combinations

11

Winch Performance Data

12

Load Chart Notes

13

Range Diagrams and  
Load Charts

14

Clamshell

19



# Index

2

# specifications

3

## Upperworks



### Engine

Hino J08E-TM Diesel, 6 cylinder, water-cooled diesel, direct fuel injection with turbocharger, 159 kW (213 HP) @ 2000 high-idle RPM. Maximum torque 797 N·m (593 lb·ft) net at 1,600 rpm (SAE J 1349).

One diesel fuel tank, 400 liters (105 gallons) capacity.

Two 12 volt 136 AH capacity batteries, 24 volt system and 60 amp alternator.

All wiring harnesses and connectors are numbered for easier servicing. Machine is equipped with individual fused branch circuits.



### Controls

Full-flow hydraulic control system for constant variable pressure to front and rear drums, boom hoist brakes and clutches. Controls respond instantly to the touch, delivering smooth function operation.

#### Relief valve pressures:

##### Load hoist, boom hoist

and propel system . . . . . 315kg/cm<sup>2</sup> (4,480 psi)

Swing system . . . . . 280 kg/cm<sup>2</sup>, (980psi)

Control system . . . . . 80 kg/cm<sup>2</sup> (1,140 psi)



### Hydraulic System

All three variable displacement piston-type pumps are driven by a heavy-duty pump drive. One of these pumps is used in the right propel circuit and hook hoist circuit, and can accommodate an optional third circuit. Another is used in the left propel circuit, boom hoist circuit and hook hoist circuit. The third variable displacement pump is used in the swing circuit. In addition, two gear pumps are used in the control system and auxiliary equipment, and two gear pumps serve the brake cooling system.

**Maximum pressure rating** . . . . . 325 kg/cm<sup>2</sup> (4,640 psi)

**Load hoist, boom hoist and propel** . . . 2 Piston pumps

**Swing** . . . . . 1 Piston pump

**Control system and auxiliary** . . . . . 2 Gear pumps

**Brake cooling system** . . . . . 2 Gear pumps

**Reservoir capacity:** . . . . . 380 liter (100 US gallon).

**Cooling:** Oil-to-air heat exchanger (plate-fin type).

**Filtration:** Full-flow and bypass type with replaceable paper element.



### Drums

Front and rear drums for load hoist powered by hydraulic variable displacement piston-type motors, driven through planetary reducers. Powered hoisting/lowering and free-fall operation is standard. Drum turn indicators for front and rear drums are also standard.

**Brakes:** spring set, hydraulically-released, multiple-disc holding brake is mounted inside the hoist motor and is operated through a counter-balance valve. An external ratchet is fitted for locking the drums.

**Drums:** front and rear 550.2 mm (21.7") P.C.D. X 545.4 mm (21.5"), grooved for 22.2 mm (7/8") wire rope.

#### Wire rope capacity:

Front drum . . . . . 265 m (869 ft) working length

Rear drum . . . . . 210 m (688 ft) working length

Storage length (each drum) . . . . . 335 m (1,099')

**Line speed:** Single line on the first drum layer

**Hoisting:** . . . . . 120m/min (390 ft/min)

**Lowering:** . . . . . 120m/min (390 ft/min)

▶ **Optional third drum:** same dimensions and specifications as front and rear drums.

Wire rope working length . . . . . 265m (869')



### Swing System

**Swing unit:** Powered by a hydraulic piston-type motor driving spur gears through planetary reducers, the swing system provides 360° rotation.

**Swing brake:** A spring-set, hydraulically released multiple-disc brake is internally fitted in swing motor.

**Swing lock:** 2 Position lock for transportation.

**Rotating bed turntable:** Single-row ball bearing with an integral internally cut swing gear.

**Swing speed:** 4.0 rpm



### Boom Support System

Single drum powered by a hydraulic axial piston motor through a planetary reducer.

Brake: A spring-set, hydraulically released multiple-disc brake is internally fitted in the boom hoist motor and operated through a counter-balance valve. An external ratchet is fitted for locking the drum.

Drum: Single drum, grooved for 16 mm (5/8") diameter wire rope. Boom Hoist reeving is 12-part line.

# specifications

## Wire Rope Capacity:

Drum 150 m (492 ft) working length.

4

**Line speed:** Single line on the first drum layer

**Hoisting** ..... 70m/min (230 ft/min)

**Lowering** ..... 70m/min (230 ft/min)



## Gantry

This high folding type gantry is fitted with a sheave frame for boom hoist reeving. Hydraulic lift is standard. It provides full up, full down positions with linkage.



## Counterweight

| QTY.                       | ITEM                                 | UNIT WEIGHT          |                 | TOTAL WEIGHT  |               |
|----------------------------|--------------------------------------|----------------------|-----------------|---------------|---------------|
|                            |                                      | kg                   | lb              | kg            | lb            |
| 2                          | <b>Carbody</b><br>Each               | 3 340                | 7,350           | 6 680         | 14,700        |
|                            |                                      | <b>Carbody Total</b> |                 | <b>6 680</b>  | <b>14,700</b> |
| 1                          | <b>Upperworks</b><br>Counterweight A | 12 500               | 27,563          | 12 500        | 27,560        |
|                            |                                      | 1                    | Counterweight B | 12 400        | 27,342        |
| <b>Upperworks Total</b>    |                                      | <b>24 900</b>        |                 | <b>54,900</b> |               |
| <b>Counterweight TOTAL</b> |                                      | <b>31 580</b>        |                 | <b>69,600</b> |               |



## Operator's Cab

Totally enclosed, full vision cab fitted with tinted safety glass. A fully adjustable, highbacked seat with arm rests permits operators to set their ideal working position. Side mounted console for auxiliary controls and instruments. An air conditioner, a signal horn, cigarette lighter, windshield wiper and inspection lamp socket are standard features.

## Controls

In front of operator are the foot pedals for front, rear and third drum (optional) brakes and foot throttle pedal. At operator's right side are the travel (propel) control levers and the function lock lever. To the operator's right front are the boom hoist control lever, front and rear winch control levers and the free-fall select switches for the front and rear winches and drum turn indicators (front /rear drum). To the operator's left front are the swing control lever and third drum (optional) control lever. To the operator's left are the crawler extend/retract lever and the positive swing lock. The left hand console contains toggle switches for travel (propel) speed, free-fall high/low select, gantry control, crane/clamshell select switch and the anti-two-block/boom overhoist switches. Directly in front of the console are the drum pawl lock for boom, front, rear and third drum (optional) and the engine ignition key. The swing parking brake and signal horn are mounted on the swing control lever.

## Gauges

Fuel gauge, engine water temperature gauge, hour meter and tachometer are located on the monitor display.

## Warning display

All potential warnings, including battery charge, engine oil pressure, air cleaner, engine oil filter, control main pressure, and hydraulic oil temperature will appear on the monitor display when a fault occurs.

## Safety device

Function lock lever, anti-two-block, boom over hoist limit switch, boom angle indicator, signal horn, boom hoist drum lock, front and rear drum lock, swing lock, swing alarm (buzzer and lamps), boom backstops and load moment indicator.

## Lowerworks



## Carbody

The durable carbody features steel welded construction with extendible axles.



## Crawlers

Crawler assemblies can be hydraulically extended for wide-track operation or retracted for transportation. Crawler belt tension adjusted with hydraulic jack and maintained by shims between idler block and frame.

## Crawler drive

The independent hydraulic propel drive is built into each crawler side frame. Each drive consists of a hydraulic motor driving a propel sprocket through a planetary gearbox. The hydraulic motor and gearbox are built into the crawler side frame within the shoe width. The track rollers are sealed for maintenance-free operation.

## Crawler brakes

Spring set, hydraulically released, multiple disc-type parking brakes are built into each propel drive.

## Steering mechanism

The hydraulic propel system provides both skid steering (driving one track only) and counter-rotating steering (driving each track in opposite direction) and differential track speed.

## Crawler shoes:

63 shoes per side, 914 mm (36") wide each crawler.

## Travel speed:

(High/Low) 1.9/1.2 km/h (1.18/0.75 mph)

## Attachments



### Boom

Welded lattice construction using tubular, high-tensile steel chords with pin connections between sections. Boom tip is open throat construction. Two idler sheaves and three point sheaves are standard.

Basic boom length 12,2 m (40') consists of the boom butt section 5,8 m (19') and boom top section 6,39 m (21').

Optional boom inserts are available to provide extension capabilities. They also have welded lattice construction with tubular, high-tension steel chords and pin connections on each one of 3,0 m (10'), 6,1 m (20'), 12,2 m (40') inserts.

Maximum total length of boom 61,0 m (200').



### Fixed Jib

The optional fixed jib employs welded lattice construction with tubular, high-tension steel chords with pin connections between sections.

Basic jib length 9,14 m (30') consists of Jib butt section 4,57 m (15') and jib top section 4,57 m (15').

Optional jib boom inserts of 3,0 m (10'), 6,1 m (20') are available for extension capabilities up to 18,3 m (60').

Maximum total length of boom and jib 54,9 m (180') + 18,3 m (60') is 76,2 m (250').

## Tools and Accessories

A set of tools and accessories are furnished.

## Optional Equipment

- ▶ Optional: Blocks and Hooks each with roller bearing sheaves grooved for 22.2 mm (7/8") diameter wire rope, and roller bearing swivel with hook latch.
- ▶ 11 t ball hook, 328 kg wedge socket for 22 mm wire rope.  
(12 USt ball hook, 722 lb wedge socket for 26 mm wire rope.)
- ▶ 19 t hook block, 400 kg with one 500 mm Nominal O.D. roller bearing sheave.
- ▶ 32 t hook block, 500 kg with two 500 mm Nominal O.D. roller bearing sheaves.
- ▶ 55 t hook block, 700 kg, four 500 mm Nominal O.D. roller bearing sheave.

(60 USt hook block, 2,398 lb, with four 24" Nominal O.D. roller bearing sheaves.)

- ▶ 80 t hook block, 800 kg, with five 500 mm Nominal O.D. roller bearing sheaves.  
(90 USt hook block, 2,892 lb with five 24" Nominal O.D. roller bearing sheaves.)
- ▶ Optional: Detachable upper boom point with one 561 mm Nominal O. D. roller bearing steel sheave grooved for 22.2 mm (7/8") rope for liftcrane.

Travel kit

Custom color

## Working Weight

Approximately 73,800 kg (162,700 lb) including upperworks and lowerworks, full upper counterweights, full carbody counterweights and 12,2 m (40') basic boom.

## Ground Pressure

Approximately 77.1 kPa (11.2 psi) with basic boom.

## Gradeability

With basic boom: 40%.

# outline dimensions

6

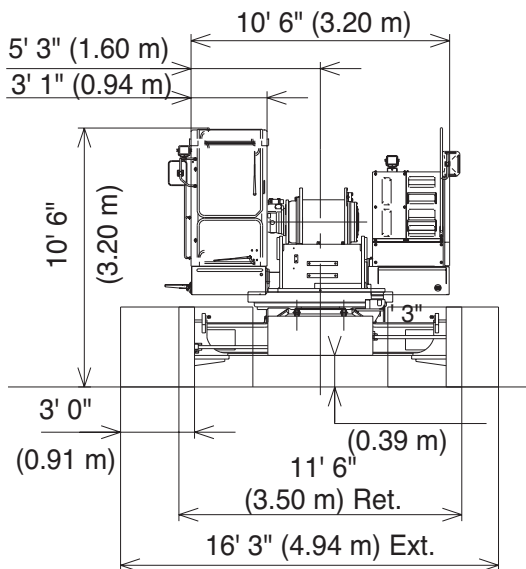
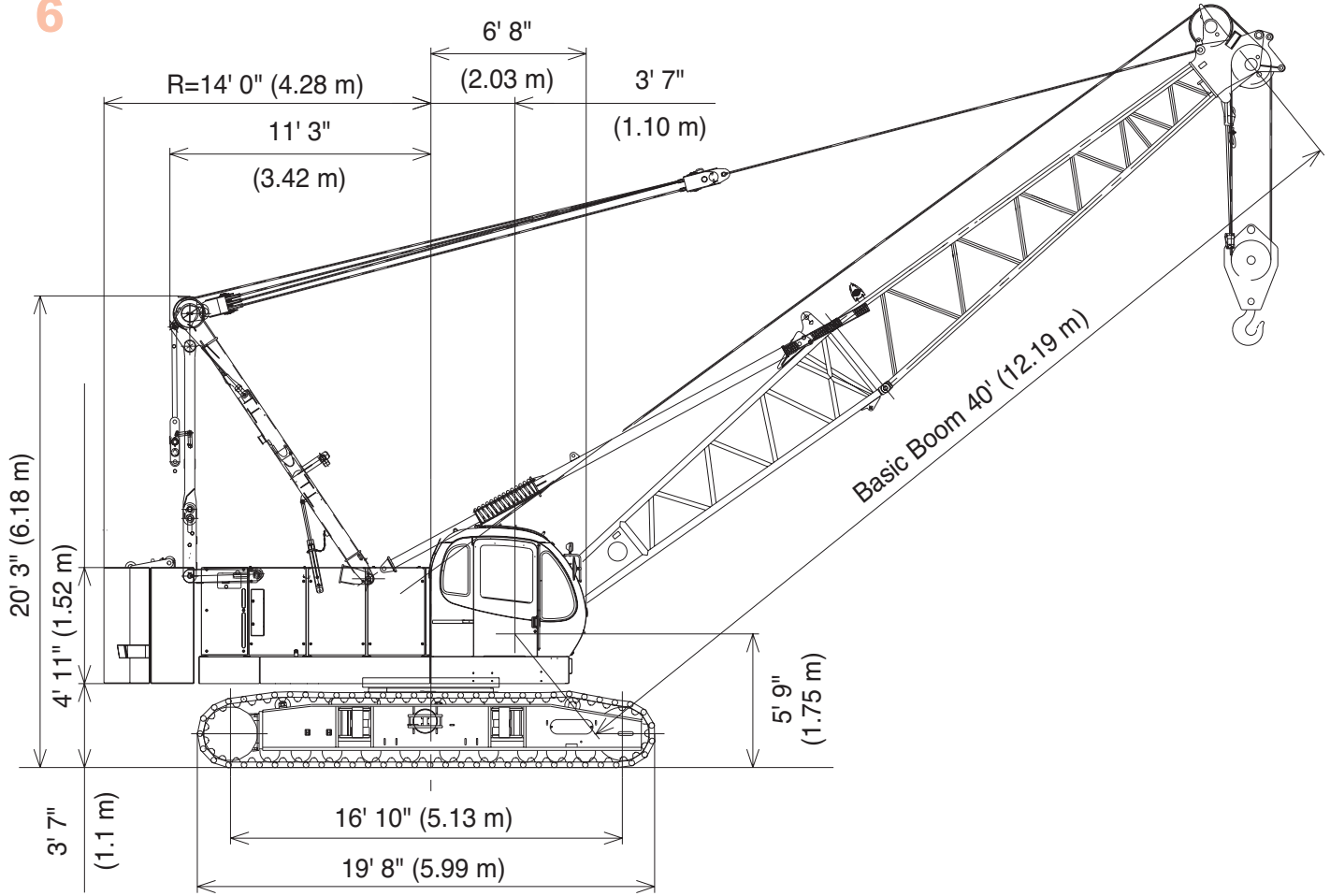

# outline dimensions

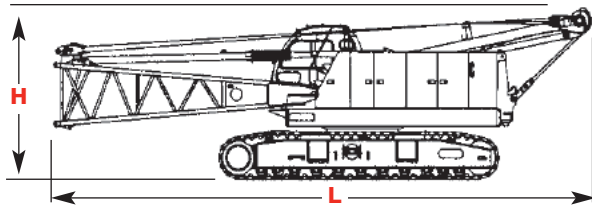

## Upperworks x 1

|        |           |           |
|--------|-----------|-----------|
| Length | 12,16 m   | 39' 11"   |
| Width  | 3,50 m    | 11' 6"    |
| Height | 3,45 m    | 11' 4"    |
| Weight | 40 820 kg | 89,980 lb |

Note: Weight includes base machine, crawler, gantry, maximum hoist and whip lines on drums, boom butt, full hydraulic fluid reservoir, and one third tank of fuel.

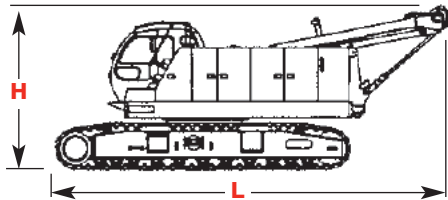

## Upperworks x 1

|        |           |           |
|--------|-----------|-----------|
| Length | 8,27 m    | 27' 2"    |
| Width  | 3,50 m    | 11' 6"    |
| Height | 3,45 m    | 11' 4"    |
| Weight | 38 700 kg | 85,350 lb |

Note: Weight includes base machine, crawler, gantry, maximum hoist and whip lines on drums, full hydraulic fluid reservoir, and one third tank of fuel.

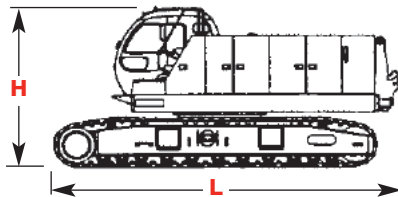

## Upperworks x 1

|        |           |           |
|--------|-----------|-----------|
| Length | 6,55 m    | 21' 6"    |
| Width  | 3,50 m    | 11' 6"    |
| Height | 3,20 m    | 10' 6"    |
| Weight | 37 000 kg | 81,600 lb |

Note: Weight includes base machine, crawler, maximum hoist and whip lines on drums, full hydraulic fluid reservoir, and one third tank of fuel.

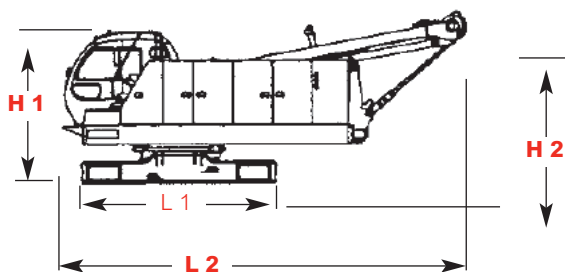

## Upperworks x 1

|          |           |           |
|----------|-----------|-----------|
| Length 1 | 3,39 m    | 11' 1"    |
| Length 2 | 6,31 m    | 23' 9"    |
| Width    | 3,20 m    | 10' 6"    |
| Height 1 | 2,81 m    | 9' 3"     |
| Height 2 | 3,06 m    | 10' 1"    |
| Weight   | 23 800 kg | 52,500 lb |

Note: Weight includes base machine, gantry, maximum hoist and whip lines on drums, full hydraulic fluid reservoir, and half tank of fuel.

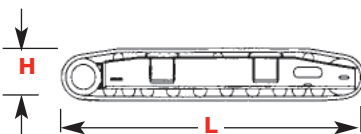

## Crawlers x 2

|        |          |           |
|--------|----------|-----------|
| Length | 5,99 m   | 19' 8"    |
| Width  | 0,91 m   | 3' 0"     |
| Height | 0,98 m   | 3' 3"     |
| Weight | 7 400 kg | 16,317 lb |

## Optional 3rd Drum & Wire Rope x 1

|        |          |          |
|--------|----------|----------|
| Weight | 1 930 kg | 4,236 lb |
|--------|----------|----------|

Note: Not illustrated).

Option

# outline dimensions

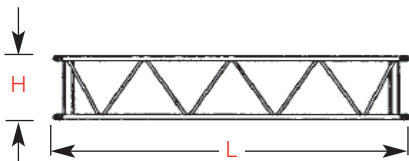
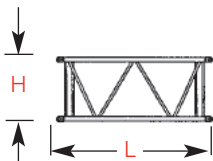
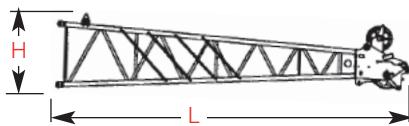
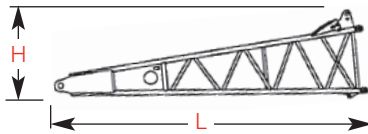
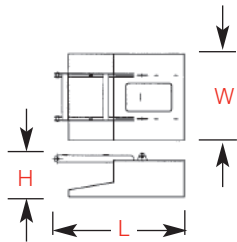
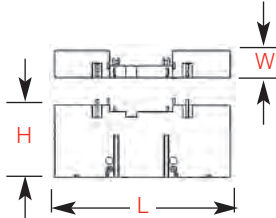
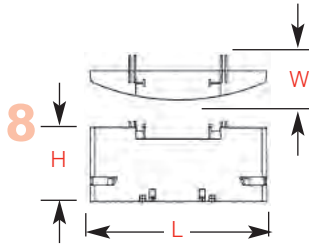

## Upper Counterweight A x 1

|        |           |           |
|--------|-----------|-----------|
| Length | 3,60 m    | 11' 10"   |
| Width  | 0,91 m    | 3' 0"     |
| Height | 1,64 m    | 5' 5"     |
| Weight | 12 500 kg | 27,563 lb |

## Upper Counterweight B x 1

|        |           |           |
|--------|-----------|-----------|
| Length | 3,60 m    | 11' 10"   |
| Width  | 0,57 m    | 1' 10"    |
| Height | 1,67 m    | 5' 6"     |
| Weight | 12 400 kg | 27,342 lb |

## Carbody Counterweight x 2

|        |          |          |
|--------|----------|----------|
| Length | 1,72 m   | 5' 8"    |
| Width  | 1,16 m   | 3' 10"   |
| Height | 0,58 m   | 1' 11"   |
| Weight | 3 340 kg | 7,350 lb |

## Boom Butt 5,8 m (19') x 1

|        |          |          |
|--------|----------|----------|
| Length | 5,97 m   | 19' 7"   |
| Width  | 1,42 m   | 4' 8"    |
| Height | 1,48 m   | 4' 10"   |
| Weight | 1 055 kg | 2,326 lb |

## Boom Top 6,4 m (21') x 1

|        |          |          |
|--------|----------|----------|
| Length | 6,90 m   | 22' 8"   |
| Width  | 1,38 m   | 4' 6"    |
| Height | 1,48 m   | 4' 10"   |
| Weight | 1 010 kg | 2,227 lb |

## Option Boom Insert 3,0 m (10') x 1, 2

|        |        |        |
|--------|--------|--------|
| Length | 3,16 m | 10' 4" |
| Width  | 1,36 m | 4' 6"  |
| Height | 1,29 m | 4' 3"  |
| Weight | 270 kg | 590 lb |

## Option Boom Insert 6,1 (20') x 1, 2

|        |        |          |
|--------|--------|----------|
| Length | 6,21 m | 20' 5"   |
| Width  | 1,36 m | 4' 6"    |
| Height | 1,29 m | 4' 3"    |
| Weight | 465 kg | 1,025 lb |

Option

# outline dimensions

9

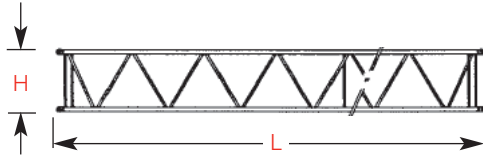

| ▶ <b>Boom Insert 12,2 m (40')</b> x 1, 2, 3 |         |          |
|---------------------------------------------|---------|----------|
| Length                                      | 12,31 m | 40' 5"   |
| Width                                       | 1,36 m  | 4' 6"    |
| Height                                      | 1,29 m  | 4' 3"    |
| Weight                                      | 860 kg  | 1,896 lb |
| Weight                                      | A875 kg | 1,929 lb |

Note: Use one "A" type insert with lug required for any boom combinations that require a 12,2 m (40') insert.

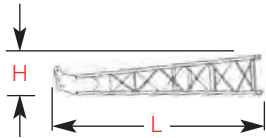

| ▶ <b>Fixed Jib Butt</b> x 1 |        |        |
|-----------------------------|--------|--------|
| Length                      | 4,81 m | 15' 9" |
| Width                       | 0,79 m | 2' 7"  |
| Height                      | 0,79 m | 2' 7"  |
| Weight                      | 200 kg | 440 lb |

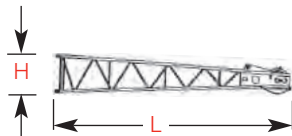

| ▶ <b>Fixed Jib Top</b> x1 |        |        |
|---------------------------|--------|--------|
| Length                    | 4,96 m | 16' 3" |
| Width                     | 0,79 m | 2' 7"  |
| Height                    | 0,79 m | 2' 7"  |
| Weight                    | 280 kg | 617 lb |

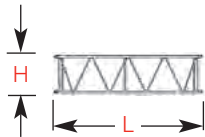

| ▶ <b>Fixed Jib Insert 3,0 m (10')</b> x 1 |        |        |
|-------------------------------------------|--------|--------|
| Length                                    | 3,12 m | 10' 3" |
| Width                                     | 0,79 m | 2' 7"  |
| Height                                    | 0,79 m | 2' 7"  |
| Weight                                    | 100 kg | 221 lb |

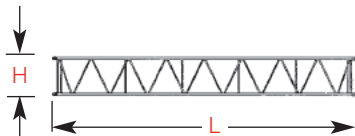

| ▶ <b>Fixed Jib Insert 6,1 m (20')</b> x 1 |        |        |
|-------------------------------------------|--------|--------|
| Length                                    | 6,16 m | 20' 3" |
| Width                                     | 0,79 m | 2' 7"  |
| Height                                    | 0,79 m | 2' 7"  |
| Weight                                    | 180 kg | 397 lb |

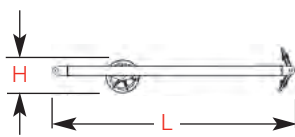

| ▶ <b>Fixed Jib Strut</b> x 1 |        |         |
|------------------------------|--------|---------|
| Length                       | 3,62 m | 11' 11" |
| Width                        | 0,84 m | 2' 9"   |
| Height                       | 0,62 m | 2' 2"   |
| Weight                       | 250 kg | 550 lb  |

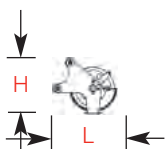

| ▶ <b>Upper Sheave</b> x 1 |        |        |
|---------------------------|--------|--------|
| Length                    | 0,83 m | 2' 9"  |
| Width                     | 0,28 m | 1' 0"  |
| Height                    | 0,74 m | 2' 5"  |
| Weight                    | 145 kg | 320 lb |

▶ Option

# self assembly

10

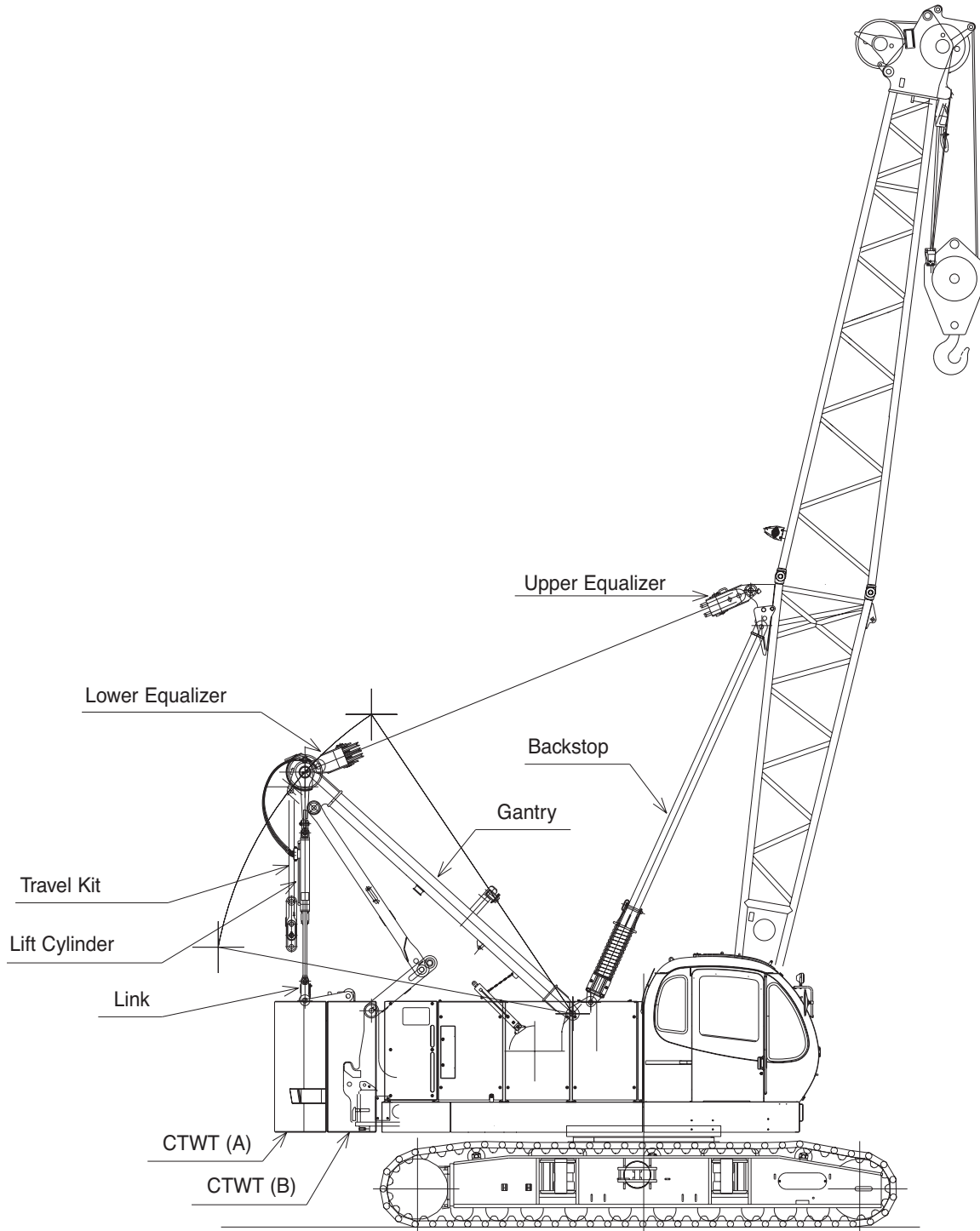

# boom combinations

## No. 8500 Heavy-Lift Boom Combinations

| Boom Length<br>m (ft) | Boom Inserts     |                  |                   |
|-----------------------|------------------|------------------|-------------------|
|                       | 3,1 m<br>(10 ft) | 6,1 m<br>(20 ft) | 12,2 m<br>(40 ft) |
| 12,2 (40)             | -                | -                | -                 |
| 15,2 (50)             | 1                | -                | -                 |
| 18,3 (60)             | 2                | -                | -                 |
| 21,3 (70)             | 1                | 1                | -                 |
| 24,4 (80)             | 2                | 1                | -                 |
| 27,4 (90)             | 1                | 2                | -                 |
| 30,5 (100)            | 2                | 2                | -                 |
| 33,5 (110)            | 1                | 1                | 1*                |
| 36,6 (120)            | 2                | 1                | 1*                |
| 39,6 (130)            | 1                | 2                | 1*                |
| 42,7 (140)            | 2                | 2                | 1*                |
| 45,7 (150)            | 1                | 1                | 2*                |
| 48,8 (160)            | 2                | 1                | 2*                |
| 51,8 (170)            | 1                | 2                | 2*                |
| 54,9 (180)            | 2                | 2                | 2*                |
| 57,9 (190)            | 1                | 1                | 3*                |
| 61,0 (200)            | 2                | 1                | 3*                |

\*Note: One 40 ft. (12,20 m) boom insert with lug 40A (12,20 m) is required for crane jib. When no jib is available, a 40 ft (12,20 m) boom can be used instead of 40A (12,20 m).

## Fixed Jib Combinations

| Jib Length<br>m (ft) | Fixed Jib Inserts |                 |
|----------------------|-------------------|-----------------|
|                      | 3,1m<br>(10 ft)   | 6,1m<br>(20 ft) |
| 9,1 (30)             | -                 | -               |
| 12,2 (40)            | 1                 | -               |
| 15,2 (50)            | -                 | 1               |
| 18,3 (60)            | 1                 | 1               |

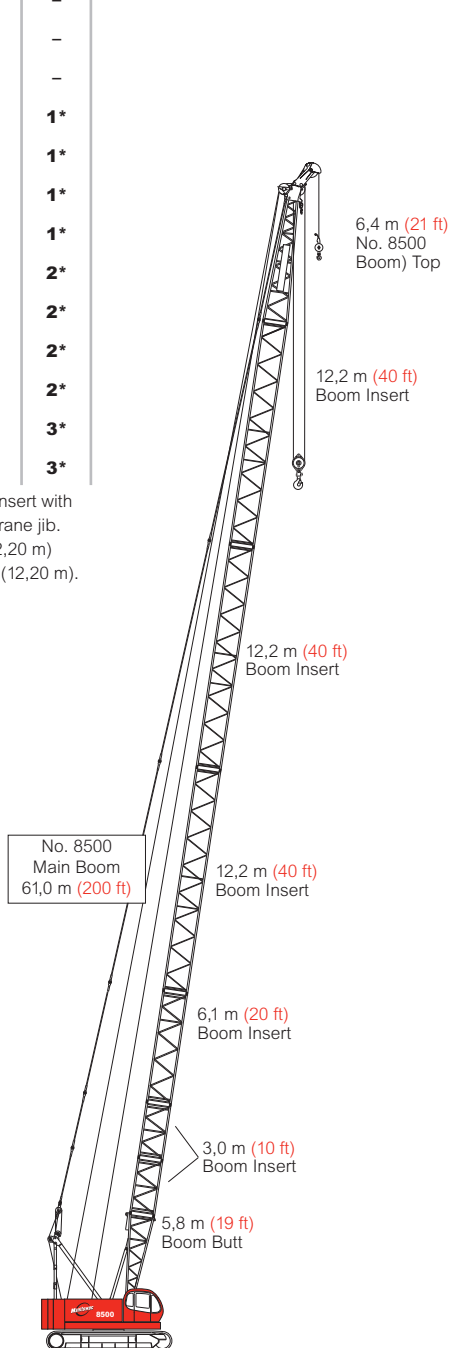

**Model 8500 Main Boom**  
61,0 m (200 ft)

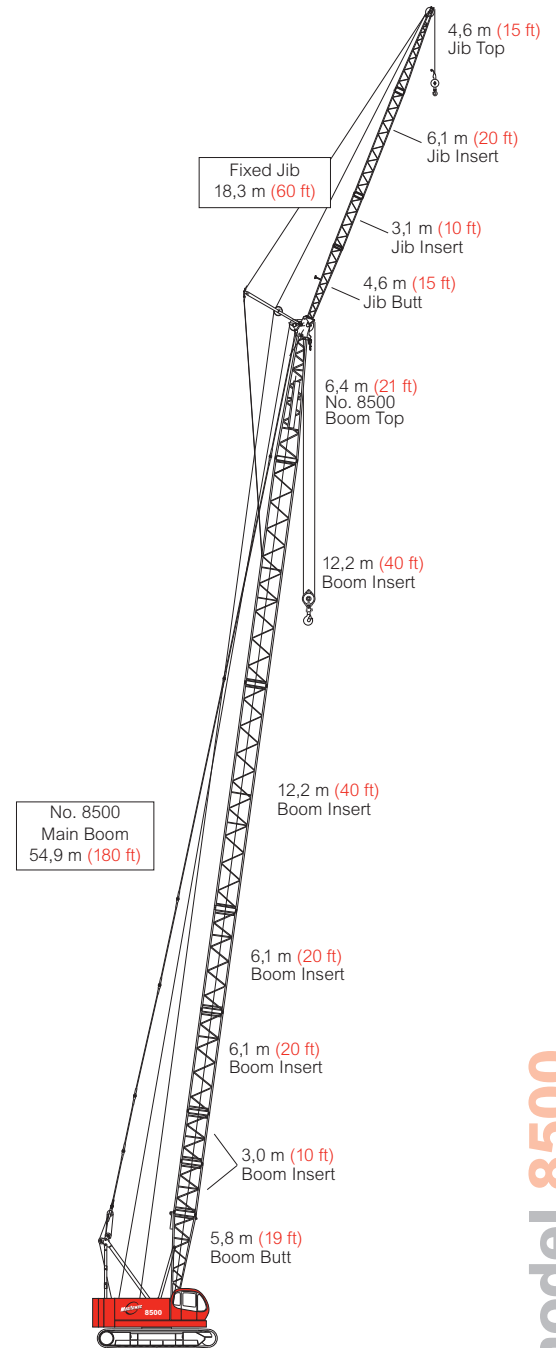

**Model 8500 Fixed Jib on Main Boom**  
73,2 m (240 ft)

# winch performance data

12

## Line Pull

|                   | Rated line pull         | * Maximum line pull       |
|-------------------|-------------------------|---------------------------|
| Front Drum        | 7,700 kg<br>(17,000 lb) | 14,500 kg<br>(32,000 lbs) |
| Rear Drum         | 7,700 kg<br>(17,000 lb) | 14,500kg<br>(32,000 lbs)  |
| Optional 3rd Drum | 7,700 kg<br>(17,000 lb) | 14,500 kg<br>(32,000 lbs) |

\* Maximum line pull is not based on wire rope strength.

## Wire Rope Specifications

| Use             | Specs                   | Diameter<br>mm (inch) | Working<br>Length<br>m (ft) | Breaking<br>Strength<br>kg (lbs) |
|-----------------|-------------------------|-----------------------|-----------------------------|----------------------------------|
| Front Drum      | IWRC C/O<br>6 X Fi (29) | 22,2 (7/8")           | 265 (869')                  | 37,015 (81,570)                  |
| Rear Drum       | IWRC C/O<br>6 X Fi (29) | 22,2 (7/8")           | 210 (688')                  | 37,015 (81,570)                  |
| Boom Hoist Drum | IWRC O/O<br>6 X WS (31) | 16,0 (5/8")           | 150 (492')                  | 18 700 (41,234)                  |
| Opt. Third Drum | IWRC C/O<br>6 X Fi (29) | 22,2 (7/8")           | 265 (869')                  | 37,015 (81,570)                  |

## Model 8500 Front and Rear Winch (Opt. Third Winch)

| Line Speed m/min (ft/min) |                    |           |           |           |           |           |           |
|---------------------------|--------------------|-----------|-----------|-----------|-----------|-----------|-----------|
| Layer                     |                    | 1         | 2         | 3         | 4         | 5         |           |
|                           | Line Pull kg (lbs) |           |           |           |           |           |           |
|                           | 0                  | 120 (394) | 128 (420) | 136 (446) | 144 (495) | 152 (499) | 160 (525) |
|                           | 2 268 (5,000)      | 120 (394) | 128 (420) | 136 (466) | 144 (495) | 152 (499) | 160 (525) |
|                           | 4 536 (10,000)     | 108 (353) | 108 (353) | 108 (353) | 108 (353) | 108 (353) | 108 (353) |
|                           | 6 804 (15,000)     | 72 (235)  | 72 (235)  | 72 (235)  | 72 (235)  | 72 (235)  | 72 (235)  |
| Rated Line Pull           | 7 711 (17,000)     | 63 (208)  | 63 (208)  | 63 (208)  | 63 (208)  | 63 (208)  | 63 (208)  |
|                           | 9 072 (20,000)     | 54 (176)  | 54 (176)  | 54 (176)  | 54 (176)  | 55 (179)  | 56 (182)  |
|                           | 11 340 (25,000)    | 43 (141)  | 44 (146)  | 45 (148)  | 45 (149)  | 45 (149)  |           |
|                           | 13 608 (30,000)    | 38 (123)  |           |           |           |           |           |

Note:

Line speeds and line pull based on single line.  
Line pulls are not based on wire rope strength

# load chart notes

13

- Rated loads included in the charts are the maximum allowable freely suspended loads at a given boom length, boom angle and load radius, and have been determined for the machine standing level on firm supporting surface under ideal operating conditions. The user must limit or de-rate rated loads to allow for adverse conditions (such as soft or uneven ground, out-of-level conditions, wind, side loads, pendulum action, jerking or sudden stopping of loads, inexperience of personnel, multiple machine lifts, and traveling with a load).
- Capacities do not exceed 75% of minimum tipping loads. Capacities based on factors other than machine stability such as structural competence are shown by asterisk \* in the charts.
- The machine must be reeved and set-up as stated in the operation manual and all the instruction manuals if these manuals are missing, obtain replacements. Boom backstops are required for all boom lengths. Gantry must be fully raised position for all operations. Crawlers must be fully extended and be locked in position. The crane must be leveled to within 1% on a firm supporting surface.
- Do not attempt to lift where no radius or load is listed as crane may tip or collapse.
- Attempting to lift more than rated loads may cause machine to tip or collapse. Do not tip machine to determine capacity.
- Weight of hooks, hook blocks, slings and other lifting devices are a part of the total load. Their total weight must be subtracted from the rated load to obtain the weight that can be lifted.
- When lifting over boom point with jib or upper boom point installed, rated loads for the boom must be deducted as shown below.

| Jib length      | Upper Boom Point | 9,1 (30')     | 12,2 (40')    | 15,2' (50')   | 18,3 (60')    |
|-----------------|------------------|---------------|---------------|---------------|---------------|
| Deduct kg (lbs) | 200 (320)        | 1 100 (2,400) | 1 500 (3,200) | 2 000 (4,200) | 2 400 (5,200) |

- The total load that can be lifted by the jib is limited by rated jib loads.
- Boom lengths for jib mounting are 24.4 m (80 ft) to 54.9 m (180 ft)
- The total load that can be lifted by the upper boom point is: the rated load for the boom (without upper boom point installed) minus 200 kg (320 lbs); however, the upper boom point rated load should not exceed 7700 kg (17,000 lbs).

- An upper boom point cannot be used on a 61 m (200 ft) boom length.
- The boom should be erected over the front of the crawlers, not laterally. When erecting and lowering the boom with a length of 54.9 m (180 ft) with jib, blocking must be placed at the end of the crawlers. See operator's manual for details.
- Least stable position is over the side.
- Maximum hoist load for number of reeving parts of line for hoist rope.

## Maximum Load for Main Boom

| No. of Parts of Line   | 1              | 2               | 3               | 4               | 5               |
|------------------------|----------------|-----------------|-----------------|-----------------|-----------------|
| Maximum Loads kg (lbs) | 7 700 (17,000) | 15 400 (34,000) | 23 100 (51,000) | 30 800 (64,000) | 38 500 (85,000) |

| No. of Parts of Line   | 6                | 7                | 8                | 9                | 10               |
|------------------------|------------------|------------------|------------------|------------------|------------------|
| Maximum Loads kg (lbs) | 46 200 (102,000) | 53 900 (119,000) | 61 600 (136,000) | 69 300 (153,000) | 80 000 (170,000) |

## Maximum Load for Fixed Jib

| No. of Parts of Line   | 1              | 2               |
|------------------------|----------------|-----------------|
| Maximum Loads kg (lbs) | 7 700 (17,000) | 10 800 (24,000) |

## Maximum Load for Upper Boom Point

| No. of Parts of Line   | 1              |
|------------------------|----------------|
| Maximum Loads kg (lbs) | 7 700 (17,000) |

- Lifting capacities listed apply only to the machine as originally manufactured and designed for Manitowoc Cranes, Inc. Modifications to this machine or use of equipment other than that specified can reduce operating capacity.
- Designed and rated to comply with ANSI Code B30.5.

Operation of this equipment in excess of rated loads or disregard of instruction voids the warranty.

# heavy-lift boom range diagram

No. 8500 Main Boom

14

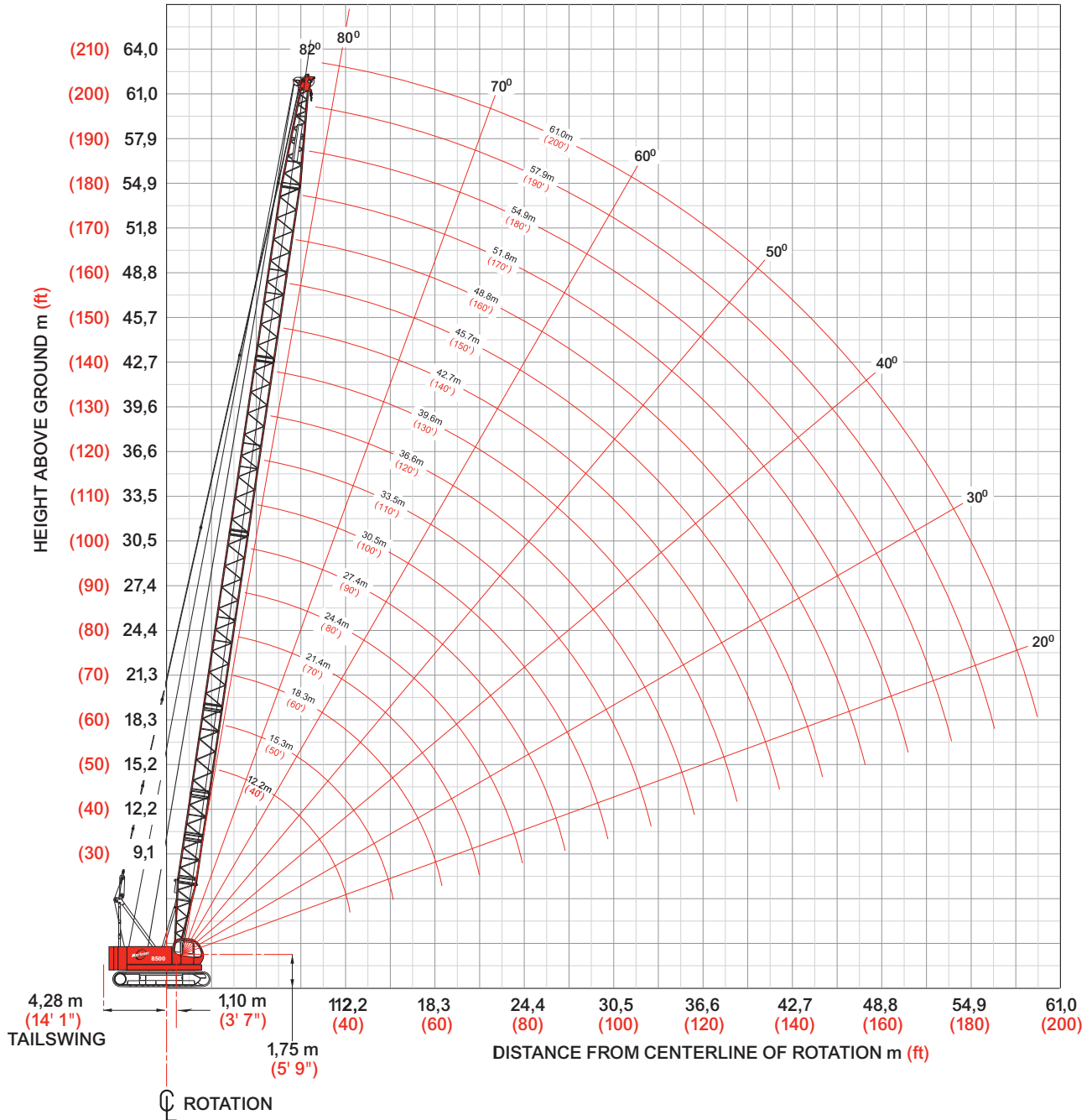

# heavy-lift load charts

15

## Model 8500 Liftcrane Boom Capacities No. 8500 Main Boom

24 900 kg (54,900 lb) Crane Counterweight, 6 700 kg (14,700 lb) Carbody Counterweight Crawler  
Extended

360° Rating

kg (lb) x 1 000

| Boom<br>m (ft) | 12,2<br>(40)    | 15,2<br>(50)    | 18,3<br>(60)    | 24,4<br>(80)    | 30,5<br>(100)  | 36,6<br>(120)  | 42,7<br>(140)  | 48,8<br>(160)  | 54,9<br>(180)  | 57,9<br>(190)  | 61,0<br>(200)  |
|----------------|-----------------|-----------------|-----------------|-----------------|----------------|----------------|----------------|----------------|----------------|----------------|----------------|
| <b>Radius</b>  |                 |                 |                 |                 |                |                |                |                |                |                |                |
| 3,0<br>(10)    | 80,0<br>(170.0) |                 |                 |                 |                |                |                |                |                |                |                |
| 3,5<br>(12)    | 76,3<br>(166.6) | —<br>(166.4)    |                 |                 |                |                |                |                |                |                |                |
| 4,0<br>(14)    | 69,5<br>(144.2) | 69,5<br>(144.0) | 69,9<br>(143.8) |                 |                |                |                |                |                |                |                |
| 4,5<br>(16)    | 61,8<br>(127.1) | 61,7<br>(126.9) | 62,0<br>(126.7) | —<br>(126.3)    |                |                |                |                |                |                |                |
| 5,5<br>(18)    | 51,2<br>(113.4) | 51,3<br>(113.2) | 51,1<br>(113.0) | 50,9<br>(112.6) |                |                |                |                |                |                |                |
| 6,0<br>(20)    | 45,4<br>(97.5)  | 45,3<br>(97.4)  | 45,2<br>(97.1)  | 45,1<br>(96.9)  | 44,6<br>(96.8) |                |                |                |                |                |                |
| 7,0<br>(24)    | 35,9<br>(74.0)  | 35,8<br>(73.8)  | 35,7<br>(73.6)  | 35,6<br>(73.3)  | 35,3<br>(73.1) | 34,9<br>(73.0) | —<br>(61.7)    |                |                |                |                |
| 8,0<br>(28)    | 29,3<br>(59.5)  | 29,4<br>(59.2)  | 29,3<br>(58.9)  | 29,2<br>(58.7)  | 29,1<br>(58.4) | 28,9<br>(58.3) | 27,4<br>(57.9) | —<br>(44.0)    |                |                |                |
| 10,0<br>(34)   | 21,7<br>(45.7)  | 21,6<br>(45.5)  | 21,5<br>(45.2)  | 21,3<br>(44.8)  | 21,2<br>(44.5) | 21,0<br>(44.3) | 21,0<br>(44.0) | 19,2<br>(42.1) | 14,9<br>(32.6) | 13,3<br>(28.8) | —<br>(25.7)    |
| 12,0<br>(40)   | 16,4<br>(34.8)  | 17,0<br>(36.8)  | 16,8<br>(36.4)  | 16,7<br>(36.0)  | 16,5<br>(35.7) | 16,4<br>(35.4) | 16,3<br>(35.1) | 16,2<br>(34.9) | 14,1<br>(31.0) | 12,5<br>(27.5) | 11,1<br>(24.4) |
| 14,0<br>(45)   |                 | 13,9<br>(31.6)  | 13,8<br>(31.2)  | 13,6<br>(30.8)  | 13,4<br>(30.5) | 13,2<br>(30.2) | 13,2<br>(29.9) | 13,1<br>(29.7) | 12,9<br>(29.2) | 11,9<br>(26.4) | 10,5<br>(23.3) |
| 16,0<br>(55)   |                 |                 | 11,6<br>(24.2)  | 11,4<br>(23.7)  | 11,2<br>(23.3) | 11,1<br>(23.0) | 11,0<br>(22.6) | 10,9<br>(22.4) | 10,7<br>(22.0) | 10,7<br>(22.1) | 9,9<br>(21.3)  |
| 22,0<br>(75)   |                 |                 |                 | 7,5<br>(15.9)   | 7,3<br>(15.4)  | 7,2<br>(15.0)  | 7,0<br>(14.6)  | 6,9<br>(14.3)  | 6,7<br>(13.9)  | 6,7<br>(13.9)  | 6,6<br>(13.7)  |
| 28,0<br>(95)   |                 |                 |                 |                 | 5,3<br>(11.2)  | 5,1<br>(10.7)  | 4,9<br>(10.2)  | 4,7<br>(10.0)  | 4,5<br>(9.5)   | 4,5<br>(9.5)   | 4,4<br>(9.3)   |
| 32,0<br>(105)  |                 |                 |                 |                 |                | 4,2<br>(9.2)   | 3,9<br>(8.7)   | 3,8<br>(8.5)   | 3,6<br>(8.0)   | 3,6<br>(8.0)   | 3,5<br>(7.8)   |
| 34,0<br>(115)  |                 |                 |                 |                 |                |                | 3,9<br>(8.1)   | 3,6<br>(7.6)   | 3,4<br>(7.2)   | 3,2<br>(6.7)   | 3,1<br>(6.5)   |
| 38,0<br>(125)  |                 |                 |                 |                 |                |                |                | 3,0<br>(6.6)   | 2,8<br>(6.2)   | 2,6<br>(5.7)   | 2,4<br>(5.4)   |
| 40,0<br>(135)  |                 |                 |                 |                 |                |                |                |                | 2,8<br>(5.9)   | 2,6<br>(5.4)   | 2,2<br>(4.5)   |
| 44,0<br>(145)  |                 |                 |                 |                 |                |                |                |                |                | 2,1<br>(4.7)   | 1,7<br>(3.7)   |
| 46,0<br>(155)  |                 |                 |                 |                 |                |                |                |                |                |                | 1,6<br>(3.3)   |
| 52,0<br>(170)  |                 |                 |                 |                 |                |                |                |                |                |                | 1,1<br>(2.5)   |

Meets ANSI B30.5 Requirements - Capacities do not exceed 75% of static tipping load.  
NOTICE: This capacity chart is for reference only and must not be used for lifting purposes.



# fixed jib load charts

17

## Model 8500 Liftcrane Jib Capacities No. 8500 Fixed Jib on Main Boom

24 900 kg (54,900 lb) Crane Counterweight, 6 700 kg (14,700 lb) Carbody Counterweight Crawler Extended

360° Rating

kg (lb) x 1 000

|                    |            | 10° Offset  |             |             |             |            | 30° Offset |            |            |            |            |            |
|--------------------|------------|-------------|-------------|-------------|-------------|------------|------------|------------|------------|------------|------------|------------|
|                    |            | 24,4        | 30,5        | 39,6        | 48,8        | 54,9       | Boom       | 24,4       | 30,5       | 39,6       | 48,8       | 54,9       |
|                    |            | m (ft)      | (80)        | (100)       | (130)       | (160)      | m (ft)     | (80)       | (100)      | (130)      | (160)      | (180)      |
| Jib 9,1 m (30 ft)  | Radius     |             |             |             |             |            |            |            |            |            |            |            |
|                    | 10,0 (30)  | 10,8 (24,0) |             |             |             |            | 10,0 (30)  |            |            |            |            |            |
|                    | 12,0 (40)  | 10,8 (24,0) | 10,8 (24,0) | 10,8 (24,0) |             |            | 12,0 (40)  | 9,0 (19,7) |            |            |            |            |
|                    | 14,0 (50)  | 10,8 (24,0) | 10,8 (24,0) | 10,8 (24,0) | 10,8 (24,0) | — (19,7)   | 14,0 (50)  | 8,3 (17,6) | 8,7 (18,5) | — (19,6)   |            |            |
|                    | 18,0 (60)  | 9,8 (21,3)  | 9,6 (20,8)  | 9,4 (20,3)  | 9,1 (19,7)  | 8,5 (18,7) | 18,0 (60)  | 7,3 (15,9) | 7,7 (16,9) | 8,2 (18,0) | 8,6 (18,9) | 8,4 (18,5) |
|                    | 24,0 (80)  | 6,7 (14,4)  | 6,4 (13,9)  | 6,2 (13,3)  | 5,9 (12,7)  | 5,7 (12,3) | 24,0 (80)  | 6,2 (13,7) | 6,5 (14,3) | 6,4 (13,7) | 6,1 (13,2) | 6,0 (12,9) |
|                    | 30,0 (100) | 4,9 (10,6)  | 4,6 (10,0)  | 4,3 (9,4)   | 4,1 (8,8)   | 3,9 (8,3)  | 30,0 (100) |            | 5,0 (—)    | 4,5 (9,7)  | 4,2 (9,1)  | 4,1 (8,7)  |
|                    | 36,0 (120) |             | 3,6 (—)     | 3,2 (6,9)   | 2,9 (6,2)   | 2,7 (5,8)  | 36,0 (120) |            |            |            | 3,0 (6,5)  | 2,8 (6,1)  |
|                    | 42,0 (140) |             |             | 2,4 (5,2)   | 2,0 (4,4)   | 1,8 (3,7)  | 42,0 (140) |            |            |            |            | 1,9 (4,0)  |
|                    | 44,0 (150) |             |             | 2,3 (—)     | 1,8 (3,6)   | 1,5 (2,9)  | 44,0 (150) |            |            |            |            | 1,6 (—)    |
|                    | 48,0 (160) |             |             |             | 1,4 (2,9)   | 1,1 (—)    | 48,0 (160) |            |            |            |            |            |
| 52,0 (170)         |            |             |             | 1,1 (—)     |             | 52,0 (170) |            |            |            |            |            |            |
| Jib 12,2 m (40 ft) | Radius     |             |             |             |             |            |            |            |            |            |            |            |
|                    | 10,0 (30)  | 10,8 (—)    | 10,8 (—)    |             |             |            | 10,0 (30)  |            |            |            |            |            |
|                    | 12,0 (40)  | 10,8 (24,0) | 10,8 (24,0) | 10,8 (—)    |             |            | 12,0 (40)  | 6,9 (—)    |            |            |            |            |
|                    | 14,0 (50)  | 10,7 (22,1) | 10,8 (24,0) | 10,8 (24,0) | 10,3 (22,8) |            | 14,0 (50)  | 6,8 (14,4) | 6,8 (15,1) |            |            |            |
|                    | 18,0 (60)  | 8,6 (18,8)  | 9,6 (20,9)  | 9,5 (20,5)  | 9,2 (20,3)  | 8,1 (17,8) | 18,0 (60)  | 5,9 (12,9) | 6,2 (13,6) | 6,6 (14,5) | 6,8 (15,1) |            |
|                    | 24,0 (80)  | 6,6 (14,5)  | 6,5 (14,1)  | 6,2 (13,5)  | 6,0 (12,9)  | 5,8 (12,5) | 24,0 (80)  | 5,0 (10,9) | 5,3 (11,6) | 5,7 (12,5) | 6,0 (13,2) | 6,2 (13,5) |
|                    | 30,0 (100) | 4,9 (10,7)  | 4,7 (10,2)  | 4,4 (9,5)   | 4,1 (8,9)   | 4,0 (8,5)  | 30,0 (100) |            | 4,7 (10,3) | 4,7 (10,0) | 4,5 (9,6)  | 4,3 (9,3)  |
|                    | 36,0 (120) |             | 3,5 (7,6)   | 3,2 (7,0)   | 2,9 (6,4)   | 2,8 (5,9)  | 36,0 (120) |            |            | 3,4 (7,4)  | 3,2 (6,9)  | 3,0 (6,5)  |
|                    | 42,0 (140) |             |             | 2,4 (5,2)   | 2,1 (4,5)   | 1,8 (3,9)  | 42,0 (140) |            |            |            | 2,3 (5,0)  | 2,1 (4,5)  |
|                    | 44,0 (150) |             |             | 2,2 (4,6)   | 1,9 (3,7)   | 1,6 (3,1)  | 44,0 (150) |            |            |            | 2,2 (—)    | 1,8 (3,6)  |
|                    | 48,0 (160) |             |             |             | 1,4 (3,0)   | 1,2 (—)    | 48,0 (160) |            |            |            |            |            |
| 52,0 (170)         |            |             |             | 1,2 (—)     |             | 52,0 (170) |            |            |            |            |            |            |

Meets ANSI B30.5 Requirements - Capacities do not exceed 75% of static tipping load.  
NOTICE: This capacity chart is for reference only and must not be used for lifting purposes.

# fixed jib load charts

18

## Model 8500 Liftcrane Jib Capacities No. 8500 Fixed Jib on Main Boom

24 900 kg (54,900 lb) Crane Counterweight, 6 700 kg (14,700 lb) Carbody Counterweight Crawler Extended

360° Rating

kg (lb) x 1 000

|                    |               | 10' Offset    |               |               |               |               | 30' Offset     |               |               |               |               |               |
|--------------------|---------------|---------------|---------------|---------------|---------------|---------------|----------------|---------------|---------------|---------------|---------------|---------------|
|                    |               | 24,4<br>(80)  | 30,5<br>(100) | 39,6<br>(130) | 48,8<br>(160) | 54,9<br>(190) | Boom<br>m (ft) | 24,4<br>(80)  | 30,5<br>(100) | 39,6<br>(130) | 48,8<br>(160) | 54,9<br>(190) |
| Jib 15,2 m (50 ft) | Radius        |               |               |               |               |               |                |               |               |               |               |               |
|                    | 10,0<br>(30)  | 9,0<br>(20.0) |               |               |               |               | 10,0<br>(30)   |               |               |               |               |               |
|                    | 12,0<br>(40)  | 9,0<br>(20.0) | 9,0<br>(20.0) | 9,0<br>(—)    |               |               | 12,0<br>(40)   |               |               |               |               |               |
|                    | 14,0<br>(50)  | 8,9<br>(18.5) | 9,0<br>(20.0) | 9,0<br>(20.0) |               |               | 14,0<br>(50)   |               |               |               |               |               |
|                    | 18,0<br>(60)  | 7,2<br>(15.6) | 7,9<br>(17.2) | 8,8<br>(19.3) | 8,7<br>(19.2) | 7,4<br>(17.0) | 18,0<br>(60)   | 4,8<br>(10.4) | 5,0<br>(10.9) | 5,2<br>(11.4) | 5,1<br>(—)    |               |
|                    | 24,0<br>(80)  | 5,5<br>(12.0) | 6,1<br>(13.3) | 6,3<br>(13.6) | 6,1<br>(13.1) | 5,9<br>(12.7) | 24,0<br>(80)   | 4,0<br>(8.7)  | 4,2<br>(9.2)  | 4,5<br>(9.8)  | 4,7<br>(10.3) | 4,8<br>(10.6) |
|                    | 30,0<br>(100) | 4,4<br>(9.7)  | 4,7<br>(10.3) | 4,5<br>(9.7)  | 4,2<br>(9.1)  | 4,0<br>(8.7)  | 30,0<br>(100)  | 3,4<br>(7.6)  | 3,7<br>(8.0)  | 3,9<br>(8.7)  | 4,2<br>(9.2)  | 4,3<br>(9.5)  |
|                    | 36,0<br>(120) | 3,9<br>(8.6)  | 3,6<br>(7.7)  | 3,3<br>(7.1)  | 3,0<br>(6.5)  | 2,8<br>(6.0)  | 36,0<br>(120)  |               |               | 3,5<br>(7.6)  | 3,3<br>(7.1)  | 3,1<br>(6.8)  |
|                    | 42,0<br>(140) |               | 2,9<br>(—)    | 2,5<br>(5.7)  | 2,0<br>(4.6)  | 1,9<br>(4.0)  | 42,0<br>(140)  |               |               |               | 2,4<br>(5.2)  | 2,2<br>(4.8)  |
|                    | 44,0<br>(150) |               |               | 2,2<br>(4.6)  | 1,8<br>(3.1)  | 1,6<br>(3.2)  | 44,0<br>(150)  |               |               |               | 2,2<br>(—)    | 2,0<br>(3.9)  |
|                    | 48,0<br>(160) |               |               | 1,9<br>(4.0)  | 1,3<br>(—)    | 1,2<br>(—)    | 48,0<br>(160)  |               |               |               |               | 1,5<br>(3.1)  |
|                    | 52,0<br>(170) |               |               |               | 1,2<br>(—)    |               | 52,0<br>(170)  |               |               |               |               |               |

|                    |               | 24,4<br>(80)  | 30,5<br>(100) | 39,6<br>(130) | 48,8<br>(160) | 54,9<br>(190) | Boom<br>m (ft) | 24,4<br>(80) | 30,5<br>(100) | 39,6<br>(130) | 48,8<br>(160) | 54,9<br>(190) |
|--------------------|---------------|---------------|---------------|---------------|---------------|---------------|----------------|--------------|---------------|---------------|---------------|---------------|
| Jib 18,3 m (60 ft) | Radius        |               |               |               |               |               |                |              |               |               |               |               |
|                    | 10,0<br>(30)  |               |               |               |               |               | 10,0<br>(30)   |              |               |               |               |               |
|                    | 12,0<br>(40)  | 8,1<br>(18.0) | 8,1<br>(—)    |               |               |               | 12,0<br>(40)   |              |               |               |               |               |
|                    | 14,0<br>(50)  | 8,0<br>(16.3) | 8,1<br>(17.6) | 8,1<br>(18.0) |               |               | 14,0<br>(50)   |              |               |               |               |               |
|                    | 18,0<br>(60)  | 6,3<br>(13.7) | 6,9<br>(15.0) | 7,6<br>(16.7) | 8,0<br>(17.8) | 6,8<br>(15.0) | 18,0<br>(60)   | 4,0<br>(8.9) | 3,9<br>(—)    |               |               |               |
|                    | 24,0<br>(80)  | 4,8<br>(10.4) | 5,3<br>(11.5) | 6,0<br>(13.0) | 6,1<br>(13.2) | 5,9<br>(12.8) | 24,0<br>(80)   | 3,3<br>(7.3) | 3,6<br>(7.7)  | 3,7<br>(8.1)  | 3,9<br>(8.5)  | 3,9<br>(8.7)  |
|                    | 30,0<br>(100) | 3,8<br>(8.3)  | 4,3<br>(9.3)  | 4,5<br>(9.7)  | 4,2<br>(9.1)  | 4,1<br>(8.7)  | 30,0<br>(100)  | 2,8<br>(6.2) | 3,0<br>(6.6)  | 3,2<br>(7.1)  | 3,4<br>(7.5)  | 3,5<br>(7.7)  |
|                    | 36,0<br>(120) | 3,2<br>(7.0)  | 3,6<br>(7.8)  | 3,3<br>(7.1)  | 3,0<br>(6.5)  | 2,8<br>(6.1)  | 36,0<br>(120)  |              | 2,7<br>(5.9)  | 2,9<br>(6.3)  | 3,1<br>(6.7)  | 3,2<br>(7.0)  |
|                    | 42,0<br>(140) |               | 2,8<br>(6.0)  | 2,5<br>(5.4)  | 2,2<br>(4.7)  | 1,9<br>(4.1)  | 42,0<br>(140)  |              |               | 2,6<br>(5.8)  | 2,5<br>(5.3)  | 2,3<br>(5.0)  |
|                    | 44,0<br>(150) |               | 2,6<br>(—)    | 2,3<br>(4.7)  | 1,9<br>(3.9)  | 1,7<br>(3.3)  | 44,0<br>(150)  |              |               |               | 2,2<br>(4.5)  | 2,1<br>(4.1)  |
|                    | 48,0<br>(160) |               |               | 1,9<br>(4.0)  | 1,5<br>(3.1)  | 1,2<br>(2.5)  | 48,0<br>(160)  |              |               |               | 1,8<br>(3.8)  | 1,6<br>(3.3)  |
|                    | 52,0<br>(170) |               |               |               | 1,1<br>(2.5)  |               | 52,0<br>(170)  |              |               |               |               |               |

Meets ANSI B30.5 Requirements - Capacities do not exceed 75% of static tipping load.  
NOTICE: This capacity chart is for reference only and must not be used for lifting purposes.

**Boom:**

Welded lattice construction using tubular, high-tensile steel chords with pin connections between sections.

Basic boom length: 12,2 m (40 ft)

Max. boom length: 21,3 m (70 ft)

Limit on clamshell bucket weight: 2 100 kg (4,600 lb)

**Boom Component Chart**

| Boom length ft (m) | Boom arrangement         |
|--------------------|--------------------------|
| 12,2 (40)          | Base-Tip                 |
| 15,2 (50)          | Base-A-Tip               |
| 18,3 (60)          | Base-A-A-Tip, Base-B-Tip |
| 21,3 (70)          | Base-A-B-Tip             |

Base = -6,1 m (20 ft)

Insert: A = 3,1 m (10 ft)

B = 6,1 m (20 ft)

Tip = 6,1 m (20 ft)

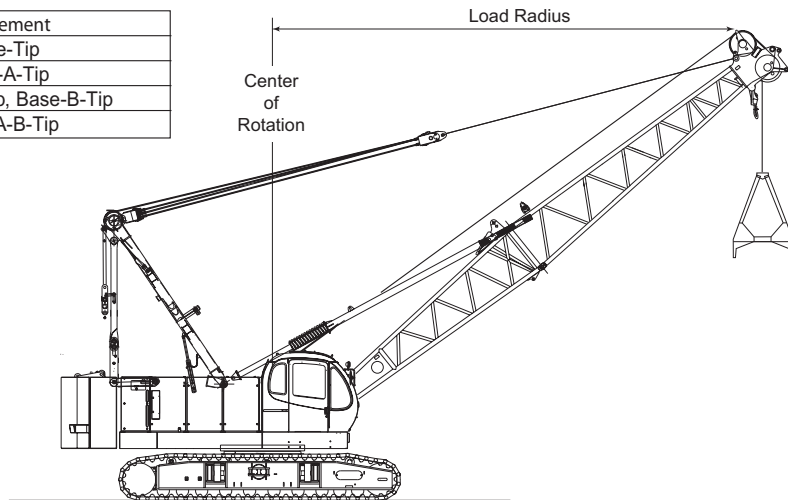

1. Figures represent maximum allowable capacity, and assume level, ground and ideal working conditions.
2. Capacities are calculated at 66% of the minimum tipping loads.
3. Capacities are maximum recommended by PCSA Standard #4. Allowances must be made by the user for such unfavorable conditions as a soft or uneven supporting surface, rapid cycle operations, or bucket suction.
4. The combined weight of the bucket and load must not exceed these capacities.
5. Boom length for clamshell operation should not exceed 21,3 m (70 ft).

## Clamshell Capacities

**12 400 kg (27,340 lb) Counterweight**

**kg (lb) x 1 000**

| Boom<br>m (ft) | 12,2<br>(40)  | 15,2<br>(50)  | 18,3<br>(60)  | 21,3<br>(70)  |
|----------------|---------------|---------------|---------------|---------------|
| <b>Radius</b>  |               |               |               |               |
| 6,7<br>(22)    | 7,3<br>(16.0) |               |               |               |
| 7,9<br>(26)    | 7,3<br>(16.0) | 7,3<br>(16.0) |               |               |
| 9,1<br>(30)    | 7,3<br>(16.0) | 7,3<br>(16.0) | 7,3<br>(16.0) |               |
| 10,9<br>(36)   | 7,3<br>(16.0) | 7,3<br>(16.0) | 7,3<br>(16.0) | 7,3<br>(16.0) |
| 12,2<br>(40)   | 7,3<br>(16.0) | 7,3<br>(16.0) | 7,3<br>(16.0) | 7,3<br>(16.0) |
| 14,0<br>(46)   |               | 7,3<br>(16.0) | 7,3<br>(16.0) | 7,3<br>(16.0) |
| 15,2<br>(50)   |               |               | 6,6<br>(14.5) | 6,5<br>(14.3) |
| 17,1<br>(56)   |               |               | 5,6<br>(12.3) | 5,6<br>(12.3) |
| 18,7<br>(60)   |               |               |               | 5,1<br>(11.2) |
| 20,1<br>(66)   |               |               |               | 4,4<br>(9.7)  |

## Americas

### USA

#### Manitowoc Crane CARE

2401 S. 30th Street,  
Manitowoc, WI 54220 USA  
Tel: + 1 920 684 6621  
Fax: + 1 920 683 6278

#### Manitowoc Crane CARE

1565 Buchanan Trail East,  
Shady Grove, PA 17256 USA  
Tel: + 1 717 597 8121  
Fax: + 1 717 593 5929

#### Manitowoc Crane CARE

16013 West Sardis Road  
Bauxite, AR 72011 USA  
Tel: + 1 501 557 5800  
Fax: + 1 501 557 5029

### Brazil

#### Manitowoc Crane CARE

Edifício: Itaim Office Tower  
Rua Gomes de Carvalho,  
1581 - 2 andar cj 205 / 206  
Vila Olímpia - SP - Cep: 04547 - 006  
Brazil  
Tel: + 55 11 3841 2741  
Fax: + 55 11 3841 2740

### Mexico

#### Manitowoc Crane CARE

Miravalles Center, piso PB,  
Suite 106 Calz San Pedro  
250 Nte. Monterrey,  
Nuevo Leon, Mexico  
Tel: + 5281 8124 0128  
Fax: + 5281 8124 0129

## Europe - Middle East - Africa

### United Kingdom

#### Manitowoc Crane CARE

Akeler House, 1 Emperor Way  
Doxford International Business Park  
Sunderland, England SR3 3XR  
Tel: + 44 191 565 6281  
Fax: + 44 191 515 7475

### France

#### Manitowoc Crane CARE

16 chaussee Jules-Cesar,  
95523 Cergy Pontoise, France  
Tel: + 33 130 313 150  
Fax: + 33 130 386 085

#### Manitowoc Crane CARE

Z.A. Les Pivolles - 5 rue  
De Catalogne, 69153 Decines  
Charpieu Cedex, France  
Tel: + 33 4 72 81 50 00  
Fax: + 33 4 72 81 50 10

### Germany

#### Manitowoc Crane CARE

Industriegelände West  
26389 Wilhelmshaven  
Postfach 1853, Germany  
Tel: + 49 4421 294 454  
Fax: + 49 4421 294 244

#### Manitowoc Crane CARE

Carl-Leverkus-Str. 14  
40764 Langenfeld, Germany  
Tel: + 49 2173 8909 0  
Fax: + 49 21738909 30

### Italy

#### Manitowoc Crane CARE

Via delle Fabbriche, 4  
12060 Niella Tanaro, Italy  
Tel: + 39 174 226 611  
Fax: + 39 174 226 667

### Netherlands

#### Manitowoc Crane CARE

Veilingkade 15  
4815 HC Breda  
Tel: + 31 76 5783999  
Fax: + 31 76 5783978

### Portugal

#### Manitowoc Crane CARE

Rua da Serra (EN 105/2)  
Apartado 3117  
4449-908 Alfena, Portugal  
Tel: + 35 1229 698 840  
Fax: + 35 1229 698 848

### United Arab Emirates (UAE)

#### Manitowoc Crane CARE

P.O. Box 75314  
Villa 354, Road 13D  
Al Quoz, Dubai  
Tel: + 97 143 381 861  
Fax: + 97 143 382 343

## Asia - Pacific

### Singapore

#### Manitowoc Crane CARE

4 Kwong Min Road  
Singapore, 628707 Singapore  
Tel: + 65 626 41188  
Fax: + 65 686 24040 (Sales/Admin)  
+ 65 686 24142 (Parts/Service)

### China

#### Manitowoc Crane CARE

No. 55 East Zhen Bei Road  
South District Zhangjiagang  
Economic Development Zone  
Zhangjiagang, Jiangsu  
215618 P R China  
Tel: + 86 512 5691 5000  
Fax: + 86 512 5691 5015

#### Manitowoc Crane CARE

RM. F. 22F Cross region Plaza  
899 Lingling Road  
Shanghai, 200030, P R China  
Tel: + 86 21 5486 1515  
Fax: + 86 21 5486 3565

#### Manitowoc Crane CARE

RM 1201-1205, #933 Zhongshan West  
Road  
Hongqiao Silver Tower  
Shanghai 200051, P R China  
Tel: + 86 21 5111 3579  
Fax: + 86 21 5111 3578

### Australia

#### Manitowoc Crane CARE

2/22 Disney Avenue, East Keilor  
VIC 3033 Australia  
Tel: + 61 03 9336 1300  
Fax: + 61 03 9336 1322

#### Manitowoc Crane CARE

142 Magowar Road  
Girraween NSW 2145 Australia  
Tel: + 61 02 9896 4433  
Fax: + 61 02 9896 3122

### Korea

#### Manitowoc Crane CARE

RM 301 Gugu Building 145-18  
Samsung-Dong, Kangnam-Ku  
Seoul 135-878 Korea  
Tel: + 82 2 508 3361  
Fax: + 82 2 508 3365

### Phillipines

#### Manitowoc Crane CARE

G/F Southwest Centre Building  
Corner Makiling Street  
Southwest Superhighway,  
Palanan, Makati City  
1235 Phillipines  
Tel: + 632 844 9437  
Fax: + 632 844 4712

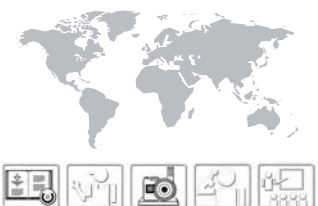

[www.manitowoccrane.com](http://www.manitowoccrane.com)