

HYDRAULICS

FRONT OF BODY HOIST

Dimension	Measure
A - Bottom Pivot Length	
B - Top Pivot Length	
C - Deck Length	
D - Hoist extended length	
E - Hoist overall length	
F - Closed Centres	
G - Bottom Trunion width	
H - Bottom Trunion Pin Length	
J - Trunion Pin Diameter	
K - Top Trunion Width	
L - Top Trunion Pin Length	
No. of Stages	

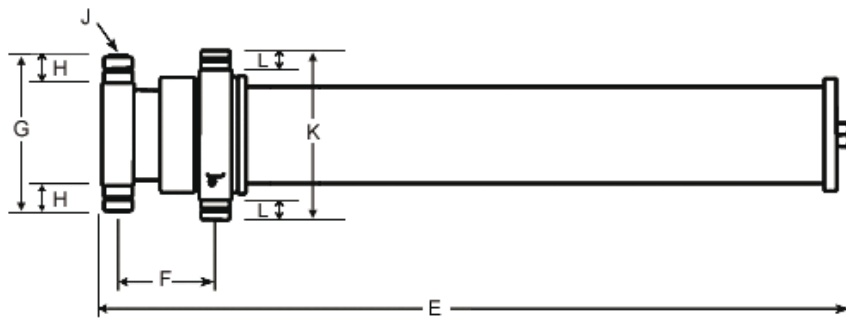
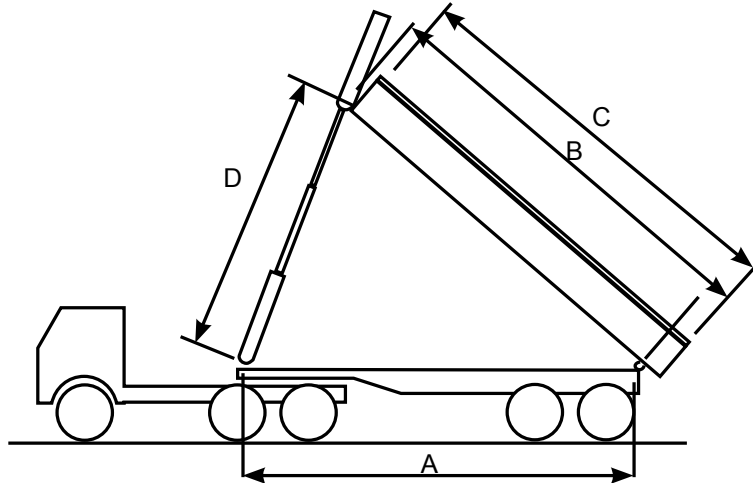

BRACKET & REAR HINGE OPTION

