

# FIFTH WHEELS

## KING PIN IDENTIFICATION

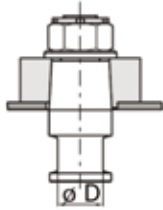

### CONE SHAPED

Pins for retention plates with cone shaped locating hole (flange).

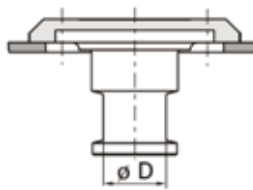

### DROP OUT

Pins for dish-shaped retention plates. The pin is bolted to the retention plate and is easy to replace from underneath.

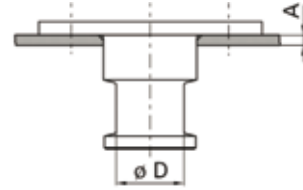

### DROP IN

Pins without a retention plate. The pin is bolted to the top plate.

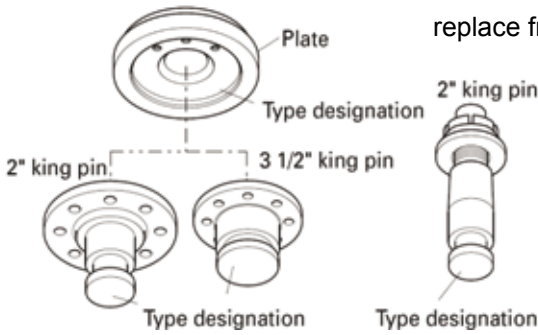

The respective type designation is stamped into the pin and the retention plate. (As shown).

Always replace mounting bolts each time you change the king pin.  
Torque to manufacturers settings.



## KZ 1008, KZ 1012

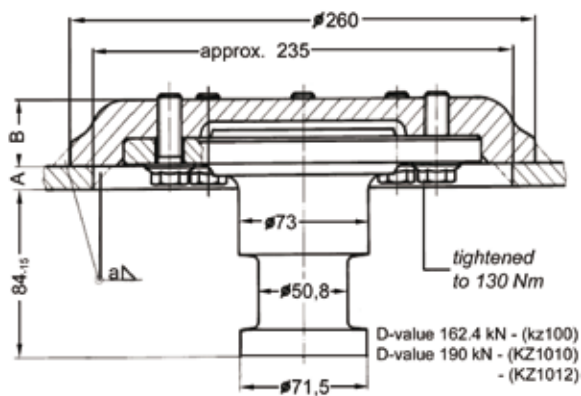

Skid Plate Thickness A (mm)	Part No.	Colour	Retention plate compl.	King pin
8mm	KZ 1008	White	KZ 1008-02	KZ 1012-01
10mm	KZ 1010	Blue	KZ 1010-02	
12mm	KZ 1012	Yellow	KZ 1412-02	

## KZ 1016

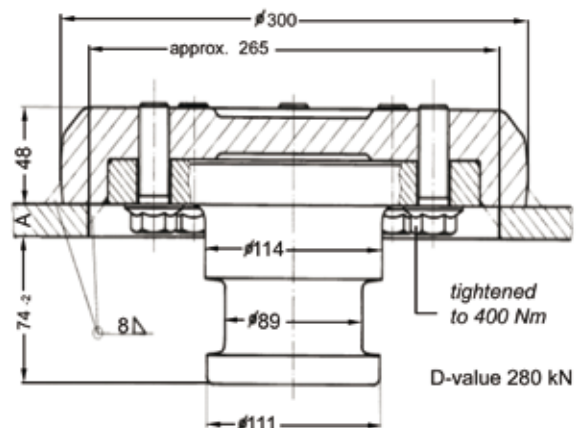

Skid Plate Thickness A (mm)	Part No.	Retention plate compl.	King pin
16mm	KZ 1016	KZ 1016-04	KZ 1016-01