

## MECHANICAL SUSPENSION

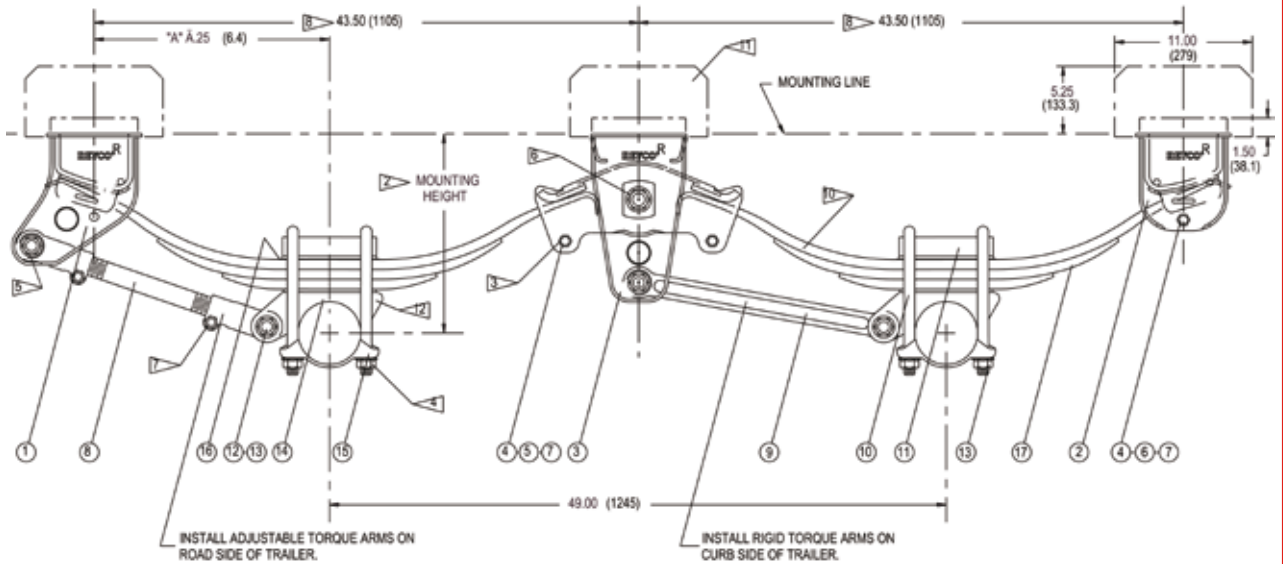

With a range of components too extensive to include in this publication, we cater for most mechanical suspension applications on the New Zealand market. We import directly from the OE Manufacturers and their suppliers.



Torque Rod Arm Pins & Bushings



Equaliser Pins & Bushings

# SUSPENSION

## MECHANICAL SUSPENSION

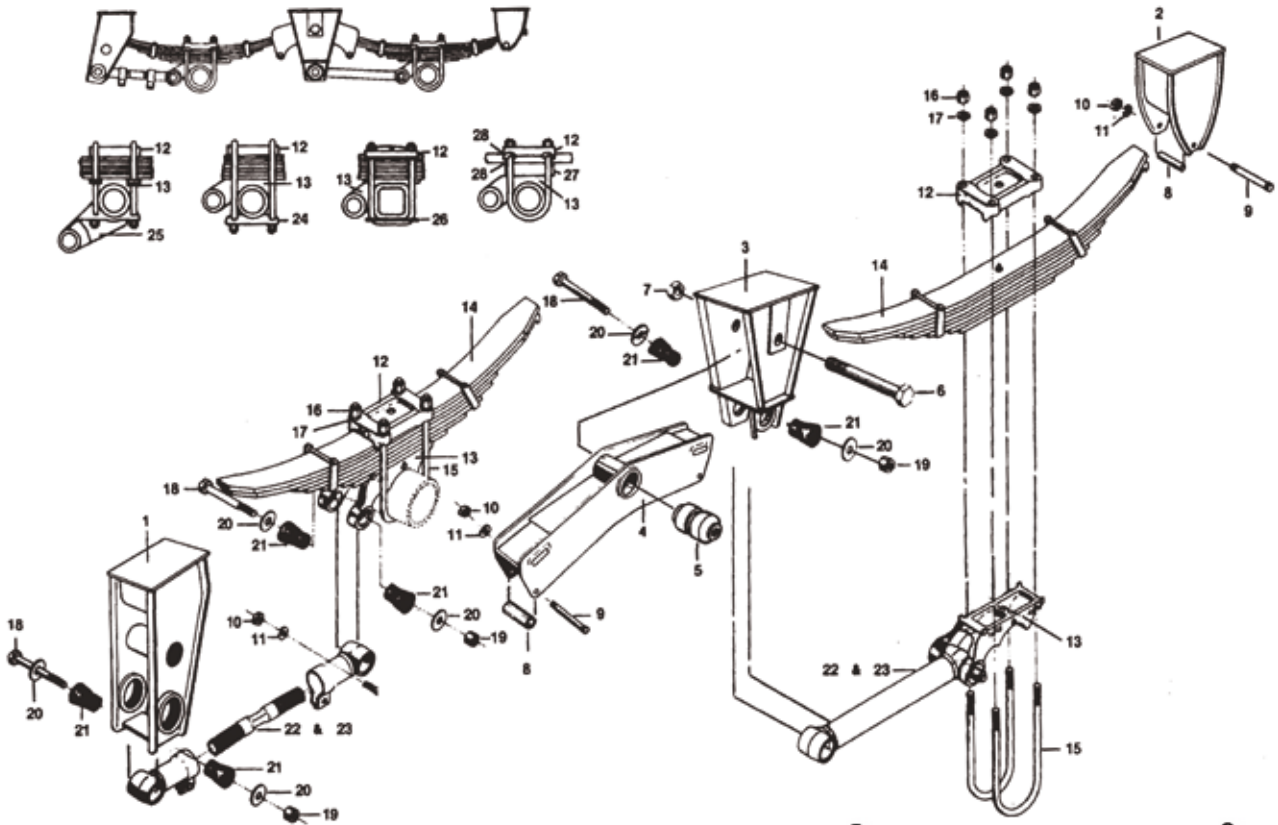

These two drawings are representative of most mechanical suspensions on the market today.

